

5994C06T

PARISOT INDUSTRIE 70800 SAINT LOUP SUR SEMOUSE -FRANCE-

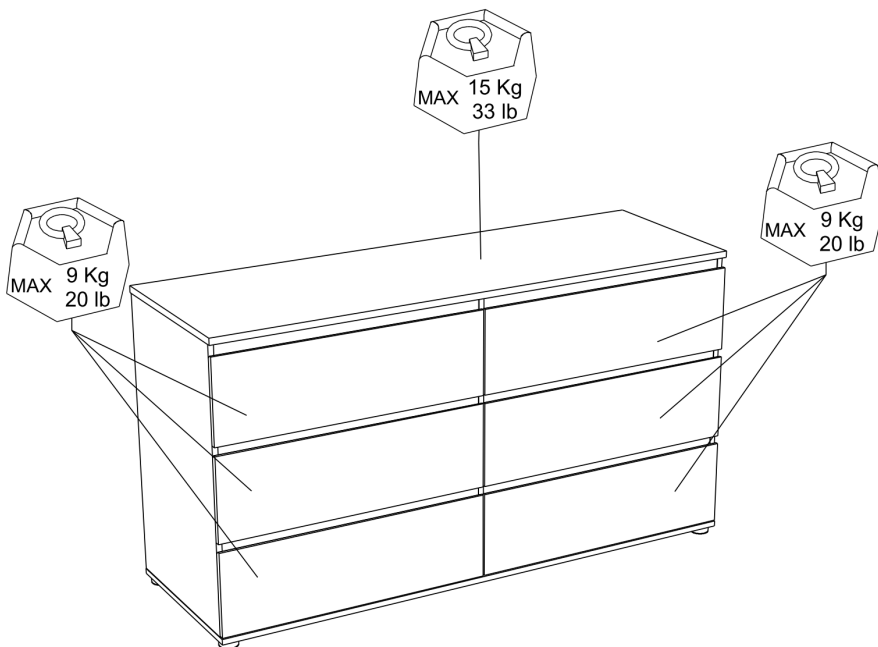

Gamme : NEO

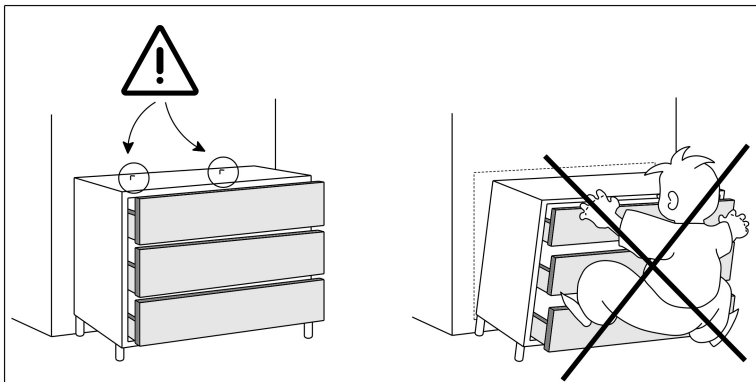

PARISOT INDUSTRIE

FR Remerciements :

Nous vous remercions d'avoir choisi un meuble créé et fabriqué par le Groupe Parisot et espérons qu'il vous donnera entière satisfaction.

EN Thanks:

Thank you for choosing furniture designed and manufactured by the Parisot Group. We hope you are totally satisfied with your purchase.

DE Danksagung:

Wir danken Ihnen für den Kauf eines Frankreich von der Parisot-Gruppe entworfenen und hergestellten Möbelstücks und hoffen, dass Sie es zu Ihrer vollkommenen Zufriedenheit finden werden.

HU Köszönet:

Köszönjük, hogy a Parisot Groupe által létrehozott és gyártott bútort választott, reméljük, hogy elégedett lesz a termékkel.

PT Agradecimentos:

Obrigado por ter escolhido um móvel concebido e fabricado pelo Grupo Parisot, esperando que seja do seu inteiro agrado.

IT Ringraziamenti:

Grazie per avere scelto un mobile progettato e fabbricato dal Gruppo Parisot. Speriamo soddisfatti appieno le vostre esigenze.

NL Bedankje:

Wij bedanken u voor de aankoop van een door de Groep Parisot ontworpen en vervaardigd meubel en hopen dat u er veel plezier aan zult beleven.

CZ Poděkování:

Děkujeme, že jste si vybrali nábytek navržený a vyrobený společností Parisot Group. Doufáme, že budete svým nákupem naprosto spokojeni.

ES Agradecimientos:

Les damos las gracias por haber elegido un mueble diseñado y fabricado por el Groupe Parisot y esperamos que sea de su total agrado.

PL Podziękowania:

Dziękujemy za wybór mebli stworzonych i wyprodukowanych przez Grupę Parisot. Mamy nadzieję, że będziecie Państwo w pełni zadowoleni z zakupu.

RO Mulțumiri:

Vă mulțumim că ați ales un articol de mobilier conceput și fabricat de Grupul Parisot și sperăm că veți fi pe deplin satisfăcuți de acesta.

RU Благодарность:

Мы благодарим вас за то, что вы выбрали мебель, созданную и произведенную Групп Паризо, и надеемся,

что вы будете полностью удовлетворены нашей продукцией.

SK Pod'akovanie:

Ďakujeme, že ste si vybrali nábytok navrhnutý a vyrobený spoločnosťou Parisot Group. Dúfame, že budete svojím nákupom absolútne spokojní.

SL Hvala:

Hvala, ker ste izbrali pohištvo, ki je dizajnirano in proizvedeno s strani Parisot Group. Upamo, da ste maksimalno zadovoljni z vašim nakupom.

TR Teşekkür ederiz:

Parisot Group tarafından tasarlanan ve üretilen bu mobilyayı seçtiğiniz için teşekkür ederiz. Ürünümüzden memnun kalmanızı ümit ederiz.

ZH 感谢 :

感谢您选择帕里索集团设计制造的家具。我们希望您对此次购买十分满意、

AR : شكر

نشكركم لإختياركم هذه القطعة من الأثاث من تصميم وتصنيع مجموعة باريسو Parisot ونتمنى أن تال رضاءكم.

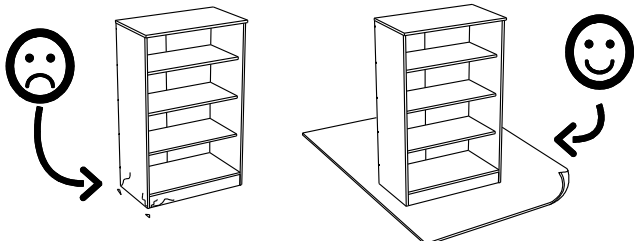
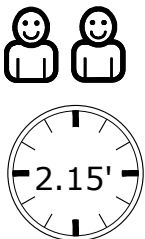
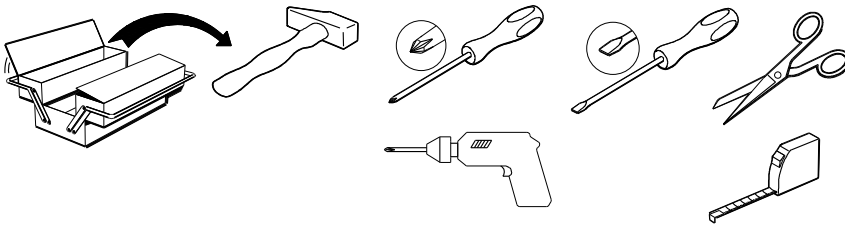

82.5cm
32 1/2"
151.5cm
59 3/4"
50cm
19 3/4"

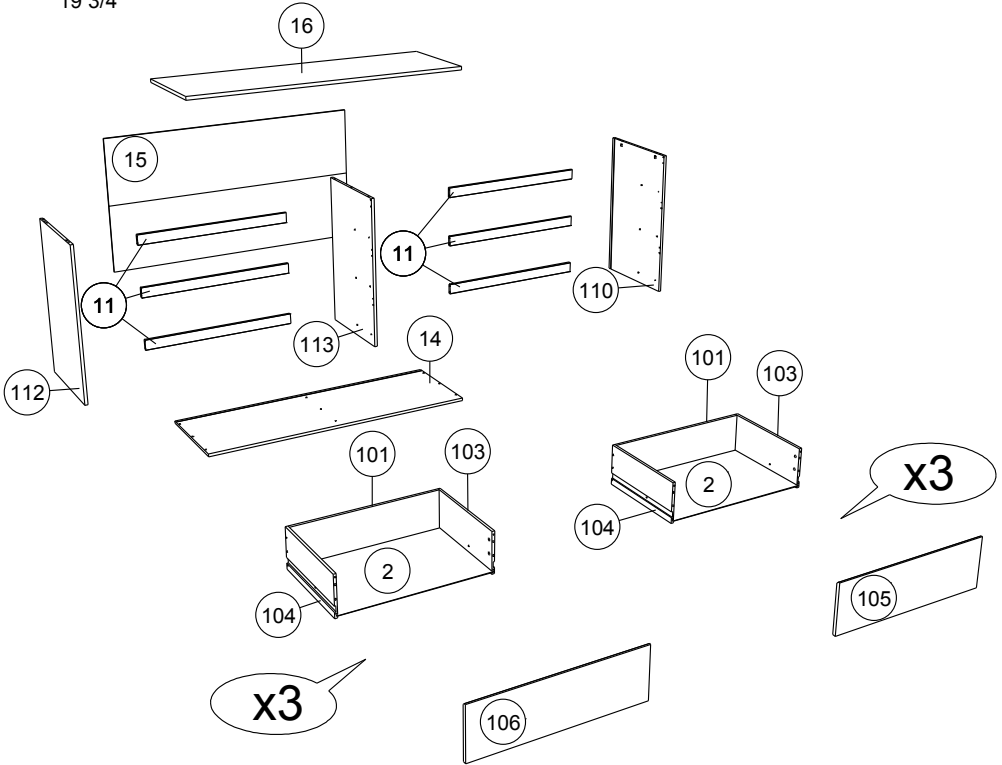

		mm			inch		
(11)	x 6	732	50	12	28 13/16	1 15/16	1/2
(105)	x 3	753	231	15	29 5/8	9 1/8	9/16
(106)	x 3	753	231	15	29 5/8	9 1/8	9/16
(113)	x 1	771	465	15	30 3/8	18 5/16	9/16
(110)	x 1	771	485	15	30 3/8	19 1/8	9/16
(112)	x 1	771	485	15	30 3/8	19 1/8	9/16
(14)	x 1	1511	500	15	59 1/2	19 11/16	9/16
(16)	x 1	1514	500	18	59 5/8	19 11/16	11/16
(104)	x 6	460	196	13	18 1/8	7 11/16	1/2
(103)	x 6	460	196	13	18 1/8	7 11/16	1/2
(101)	x 6	699	196	13	27 1/2	7 11/16	1/2
(2)	x 6	710	459	3	27 15/16	18 1/16	1/8
(15)	x 1	1495	787	3	58 7/8	31	1/8



HV x 1

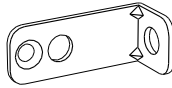

BLL x 1



EP x 14

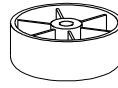

BXC x 5

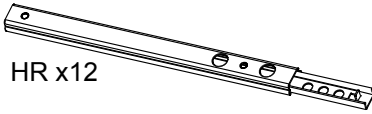

HR x 12



Ai x 6



BZG x 24

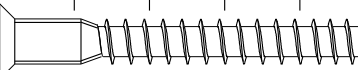
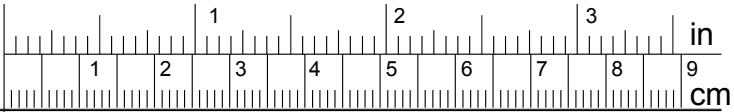

HW x 6

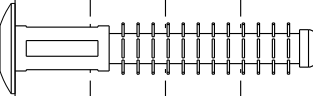

CQA x 36



ADU x 48

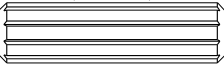
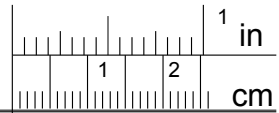

ADM x 8



BXH x 6

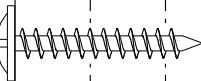

XN x 7

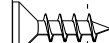

VG x 13

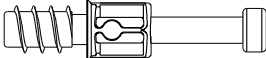

BSD x 30



ANK x 12



VR x 12



VP x 12

1

BSD x 24

ADU x24

BZG x 24

CQA x 36

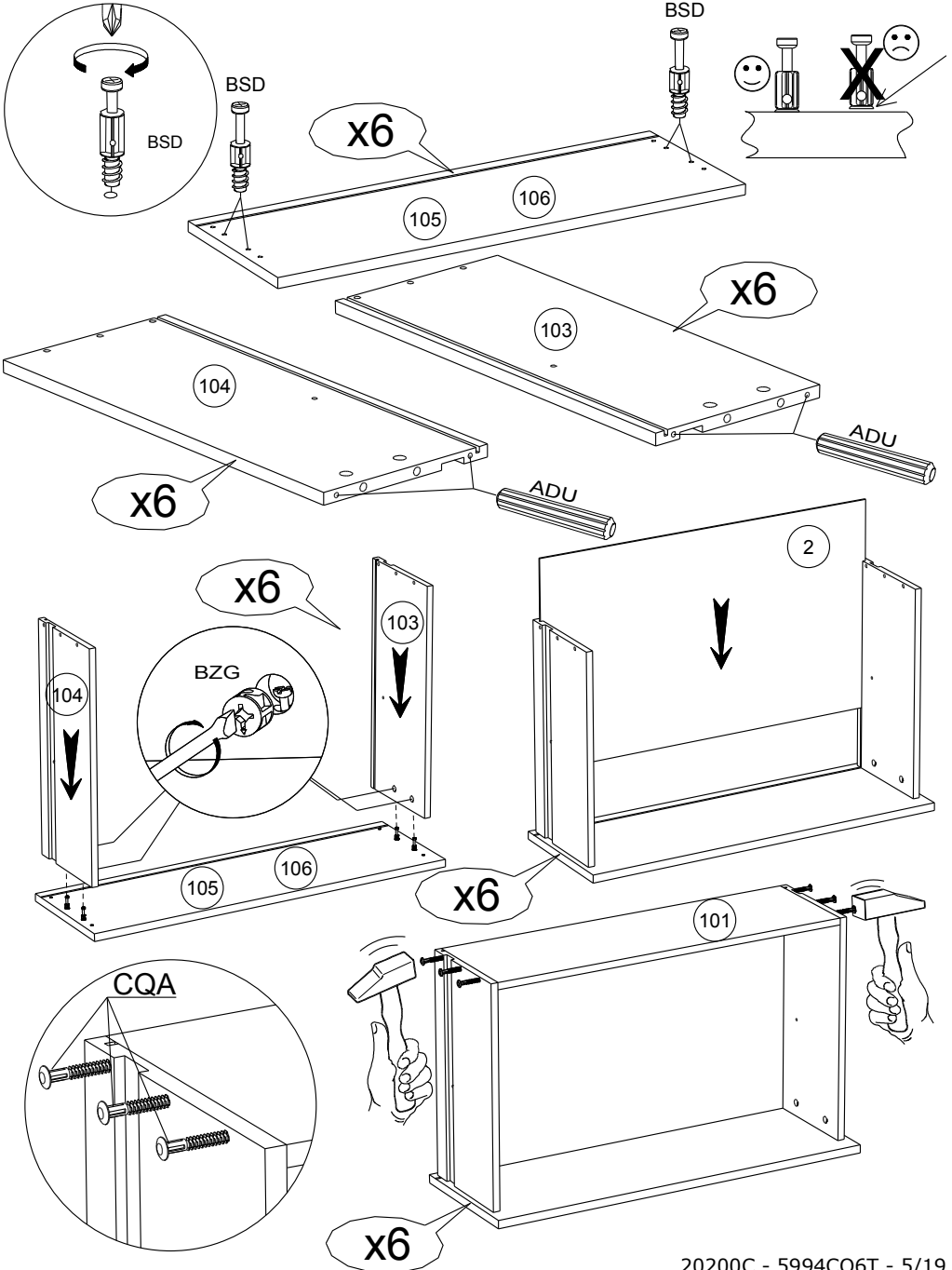

2



ANX x 12



ADM x 8



BXH x 6

ANX

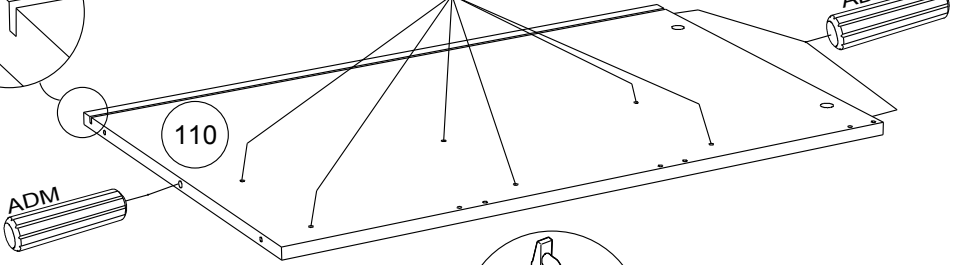
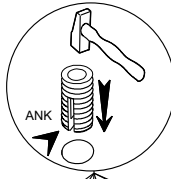
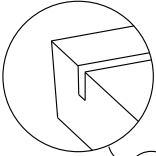
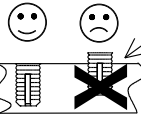

110

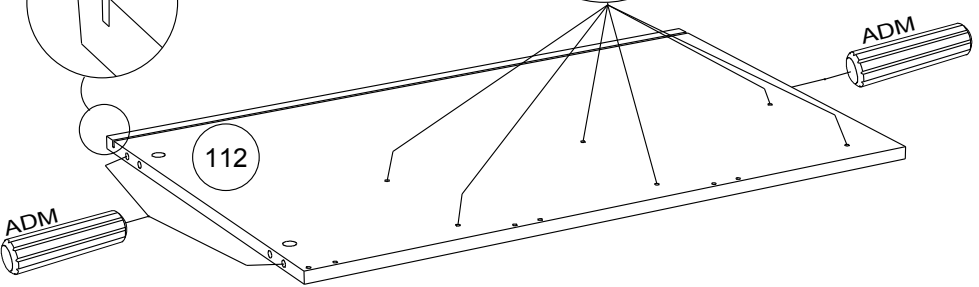
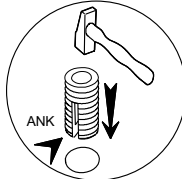
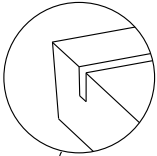

112



BXH

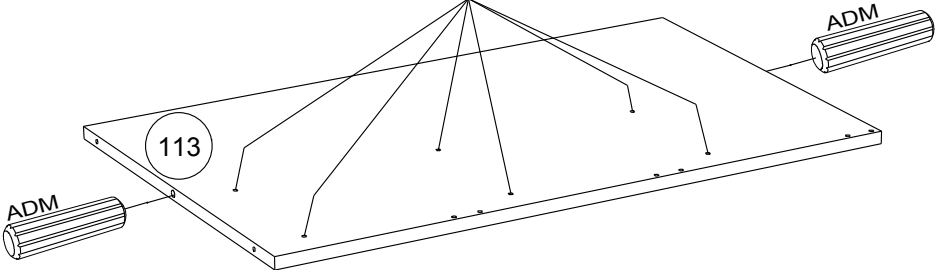

113

3

HR x3

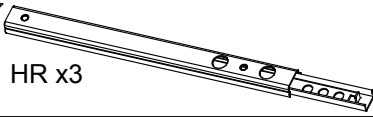

VG x6

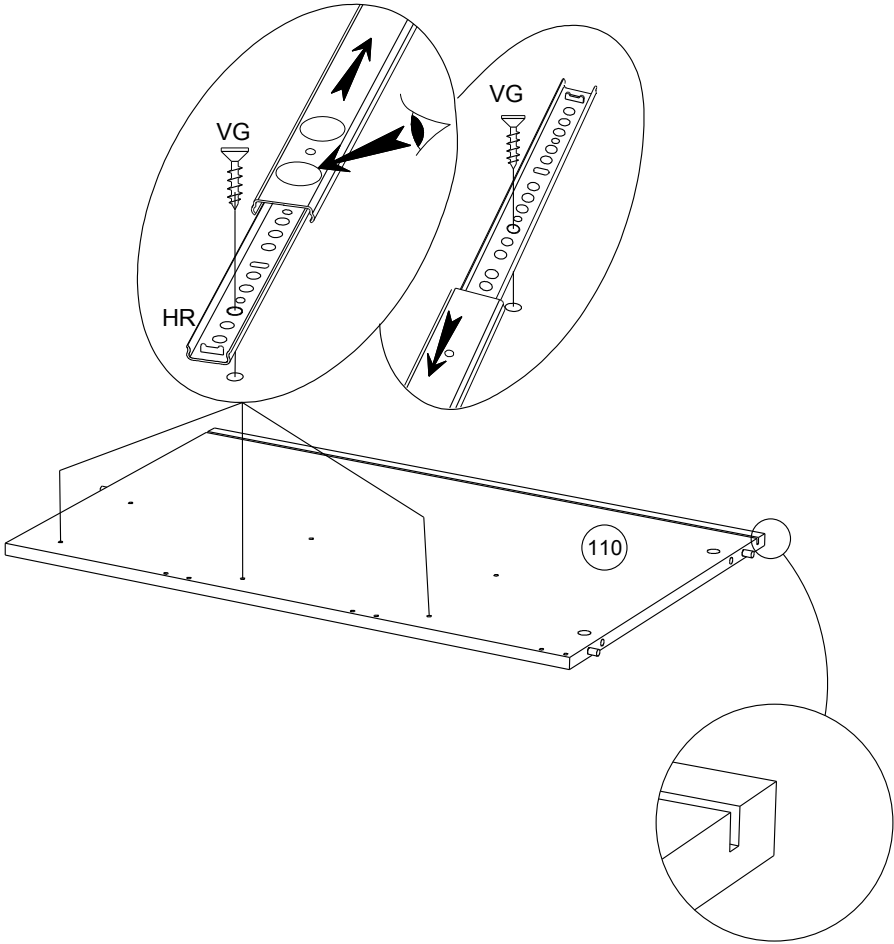

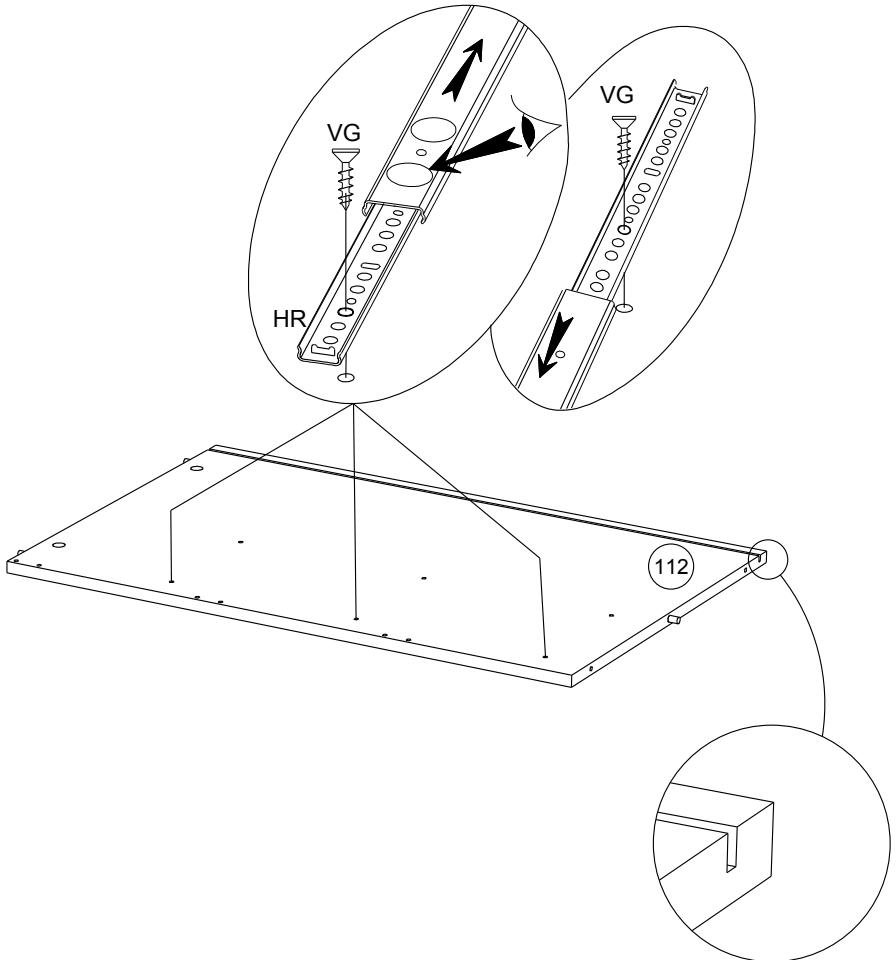
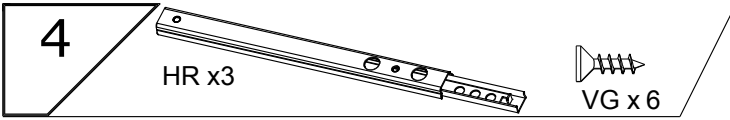

5

HR x3

VP x 6

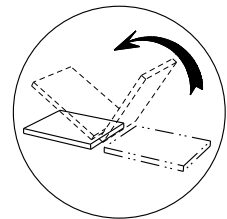
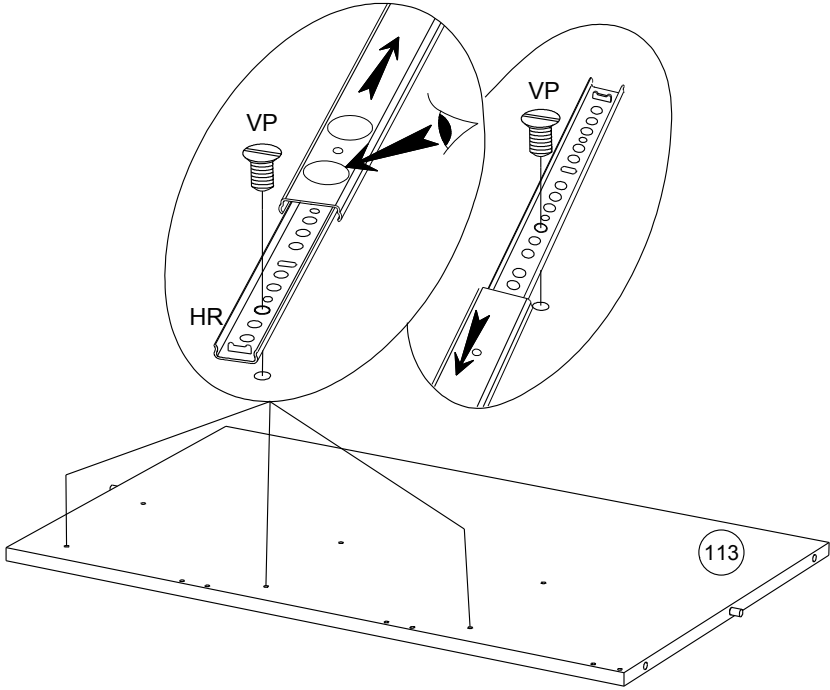

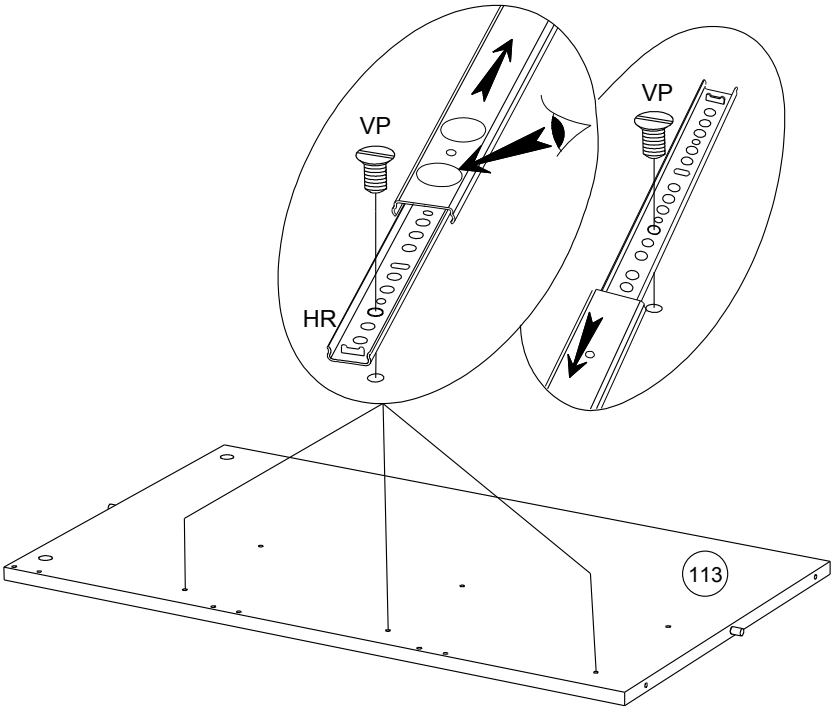
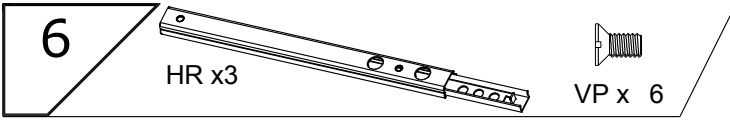

7

ADU x24

x6

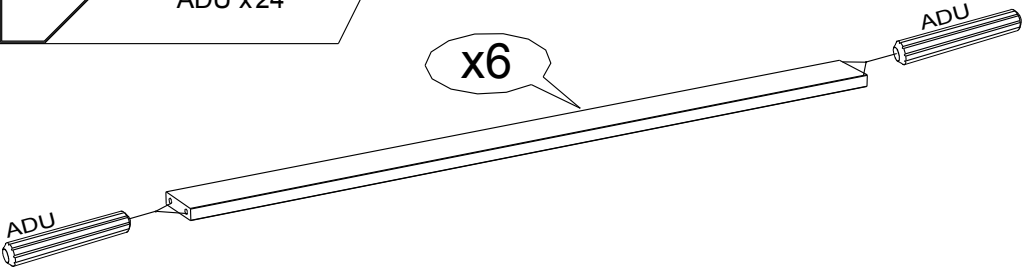

8

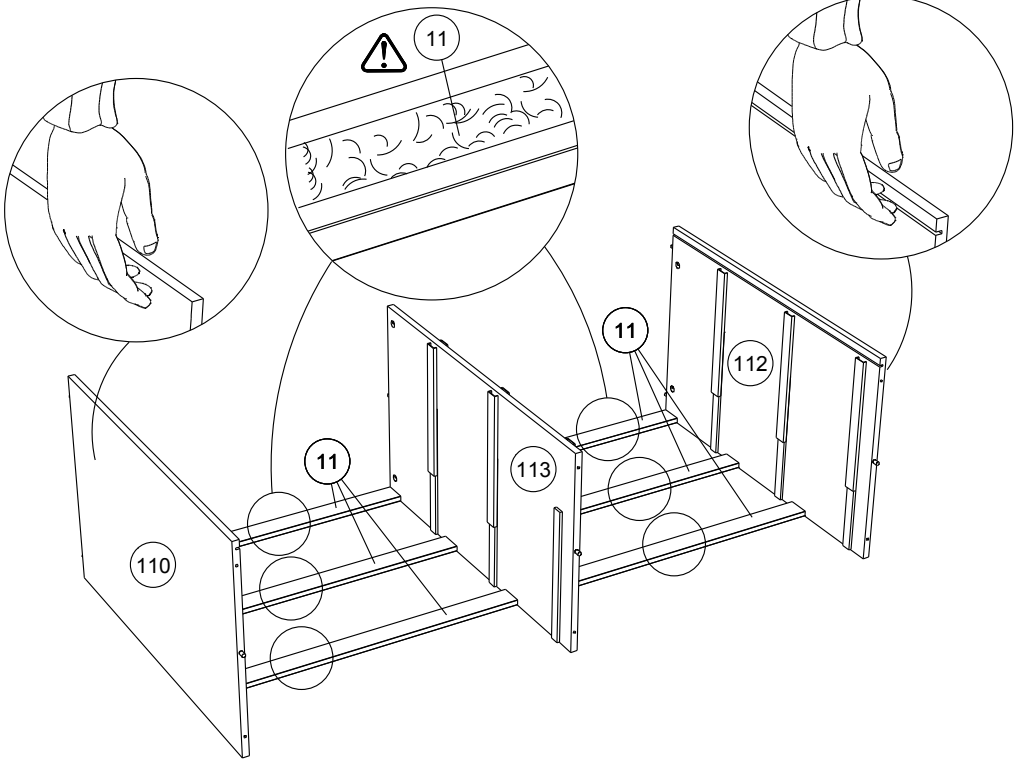
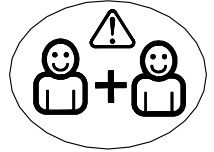

9

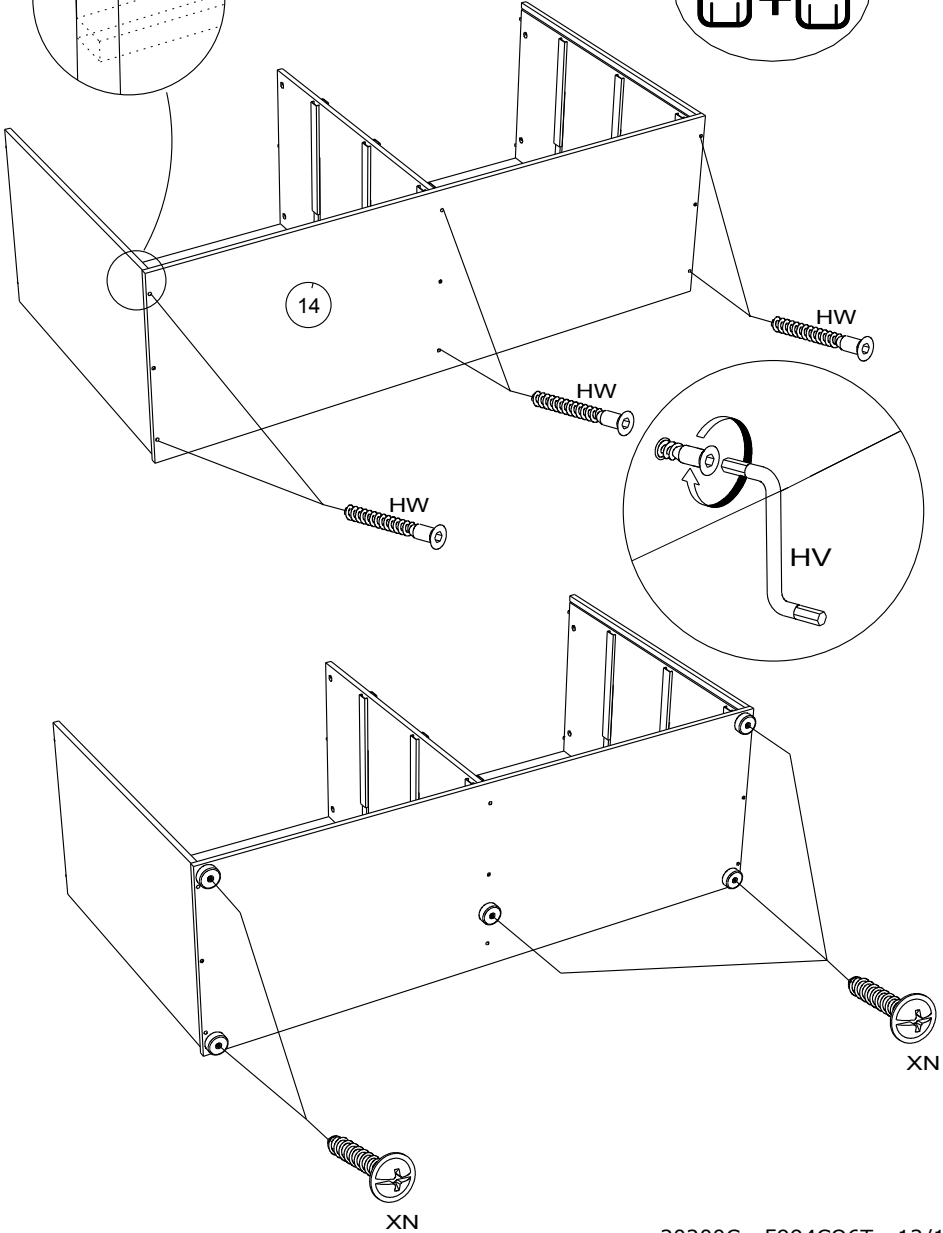
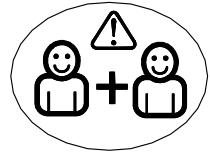
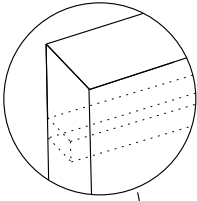
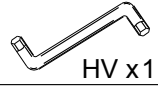
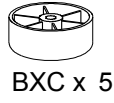
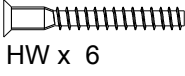

10

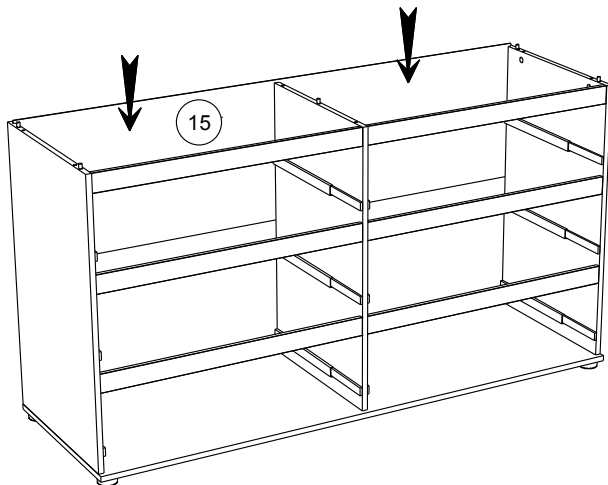

11

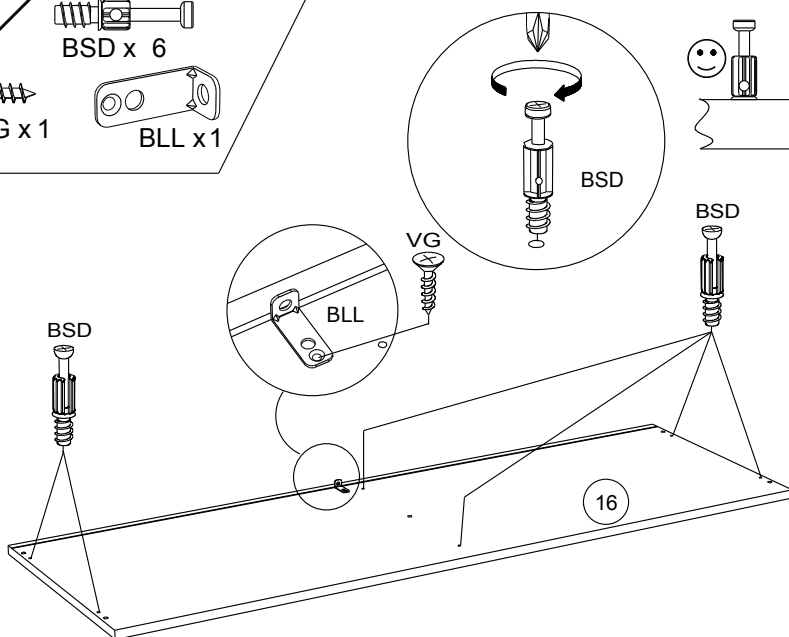
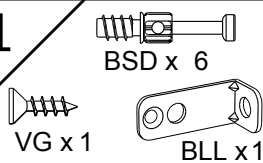

12



Ai x 6

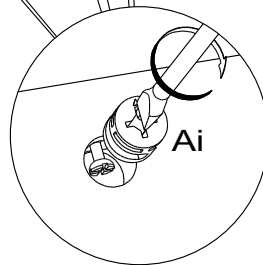
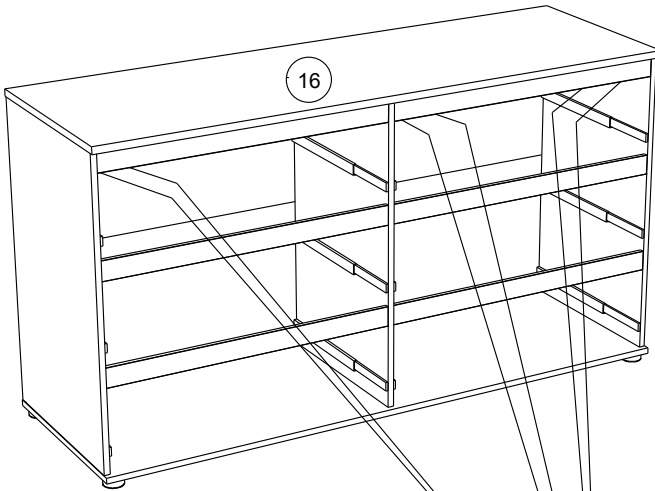

13

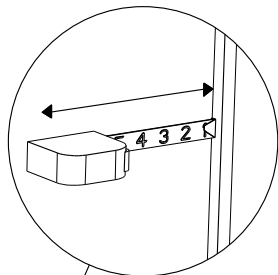
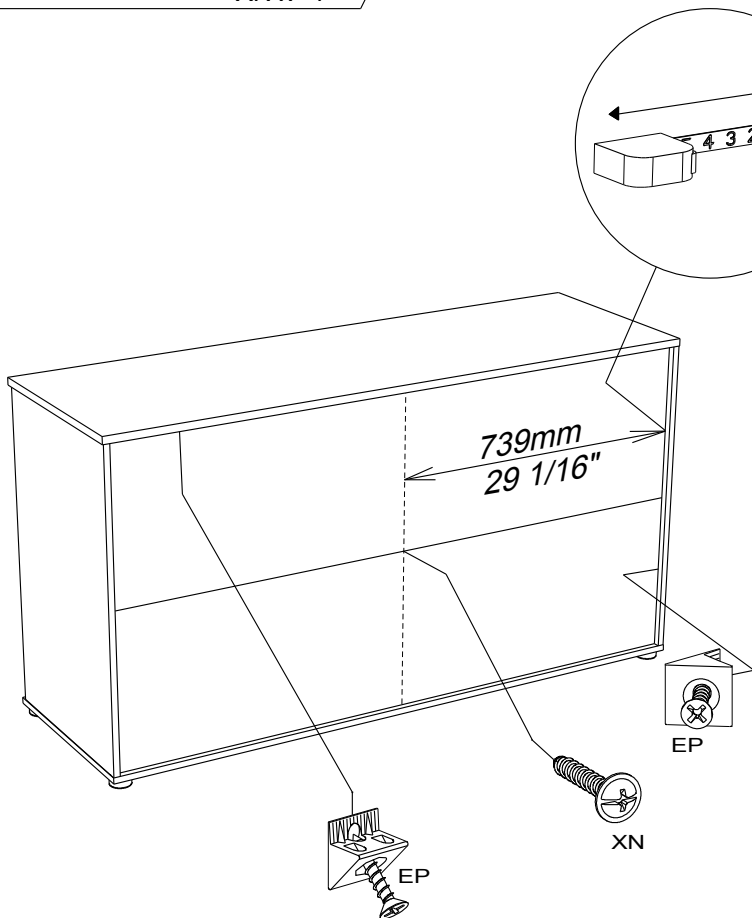

- FR OBLIGATOIRE:** Pour votre sécurité, fixation du meuble au mur.
Attention, la fixation doit être réalisée par une personne compétente car cela nécessite des chevilles adaptées à la nature de votre mur.
- EN OBLIGATORY:** For your safety, due to risk of overturning, this product must be used with the wall attachment device provided, this should be carried out by a competent person.
- DE OBLIGATORISCH:** Zu Ihrer Sicherheit, befestigen Sie das Möbel an der Wand.
Achtung: Diese Befestigung ist durch eine fachlich kompetente Person vorzunehmen.
Hierfür sind für die Bauweise Ihrer Wand geeignete Dübel einzusetzen.
- ES OBLIGATORIO:** Por su seguridad, fijar el mueble a la pared.
Advertencia: la fijación la ha de llevar a cabo por personal adecuado, ya que requiere el uso de tacos que se adapten al tipo de pared.
- PT OBRIGATÓRIO:** Para sua segurança, fixação do móvel ao muro.
Atenção: a fixação deverá ser efetuada por pessoa habilitada, visto que são necessárias cavilhas adaptadas ao tipo de parede.
- IT OBBLIGATORIO:** Avvertenza di sicurezza, il fissaggio del mobile a parete deve essere realizzato da una persona competente, in quanto l'operazione richiede l'impiego di tasselli adatti alla natura del muro.
- NL VERPLICHT:** Voor uw veiligheid, bevestiging van het meubel aan de muur.
Opgelet de bevestiging moet worden uitgevoerd door een bekwaam persoon daar dit voor uw type muur geschikte pluggen vereist.
- CZ POVINNÝ:** Z bezpečnostních důvodů, upevněte nábytek do zdi.
Pozor, upevnění je třeba svěřit kompetentní osobě, neboť vyžaduje hmoždinky vhodné pro vaši zeď.
- HU KÖTELEZŐ:** Az Ön biztonsága érdekében, a bútor falra rögzítése.
Figyelmeztetés : a rögzítés csak megfelelő szakképesítéssel rendelkező személy által végezhető el, mert a rögzítéshez a falnak megfelelő csavarokra van szükség.
- PL OBOWIĄZKOWY:** Dla bezpieczeństwa, mocowanie mebla do ściany.
Uwaga, mocowanie musi zostać wykonane przez osobę kompetentną, ponieważ wymaga to zastosowania kołków dostosowanych do rodzaju ściany.
- RO OBLIGATORIU:** Pentru securitatea dumneavoastră, fixarea mobilierului de perete.
Atenție, fixarea trebuie să fie realizată de o persoană calificată, deoarece sunt necesare dispozitive de fixare adaptate caracteristicilor peretelui dumneavoastră
- RU ОБЯЗАТЕЛЬНЫЙ :** Для вашей безопасности Крепление мебели к стене
Внимание! Крепление должно производиться опытным специалистом, т.к. для такой установки потребуются штифты, соответствующие типу вашей стены.
- SK POVINNÉ:** Z bezpečnostných dôvodov, nábytok upevnite k stene.
Dbajte na to, aby upevnenie vykonala kompetentná osoba, pretože pri upevňovaní sa vyžadujú kolíky vhodné do materiálu, z ktorého je stena vyrobená.
- SL OBVEZNO:** Za vašo varnost, Enota naj bo pritrjena na steno. Pozor: To naj stori kompetentna oseba, ker je potrebno uporabiti pravilni nosilec glede na vrsto stene ki jo uporabljate.
- TR ZORUNLU:** Güvenliğiniz için, Mobilyanın duvara sabitlenmesi
Dikkat, sabitleme işlemleri uzman biri tarafından yapılmalıdır çünkü bu işlem için duvarınızın malzemesine uygun dübellerin kullanılması gerekmektedir
- EL ΥΠΟΧΡΕΩΤΙΚΟΣ :** Για την ασφάλειά σας στερέωση των επίπλων στον τοίχο.
Προσοχή, η στερέωση πρέπει να γίνεται από ικανό άτομο, καθώς απαιτούνται σφήνες προσαρμοσμένες στη φύση του τοίχου σας.

AR واجب : لسلامتك الشخصية, تثبيت قطعة الأثاث على الحائط

تحذير، يجب أن يقوم شخص متخصص بعملية التثبيت على الحائط إذ أنها تتطلب اسفينا معيناً يتوافق مع طبيعة الحائط نفسه.

ZH 義務性 : 为了您的安全，本产品必须靠墙安装。

NB 本产品必须由专业人士安装，且您必须使用符合您的墙壁类型的罗威纤维管。

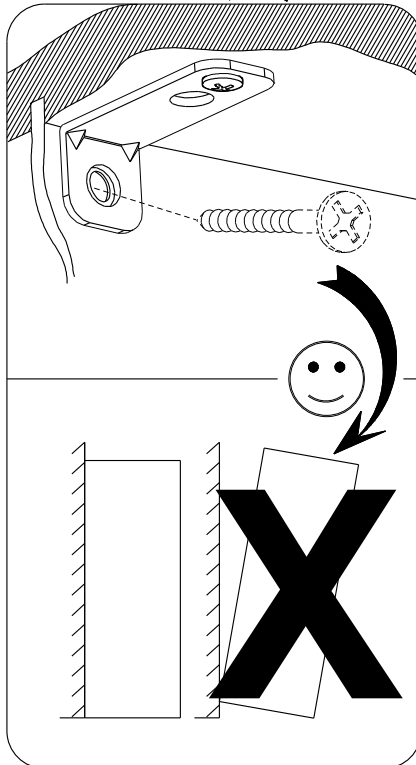
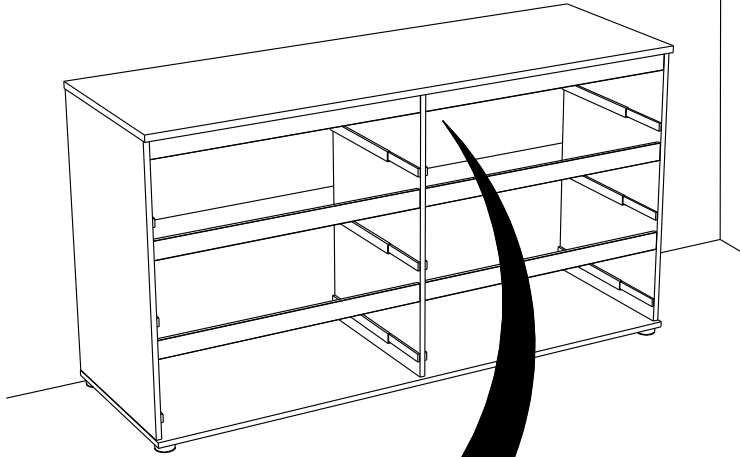

15

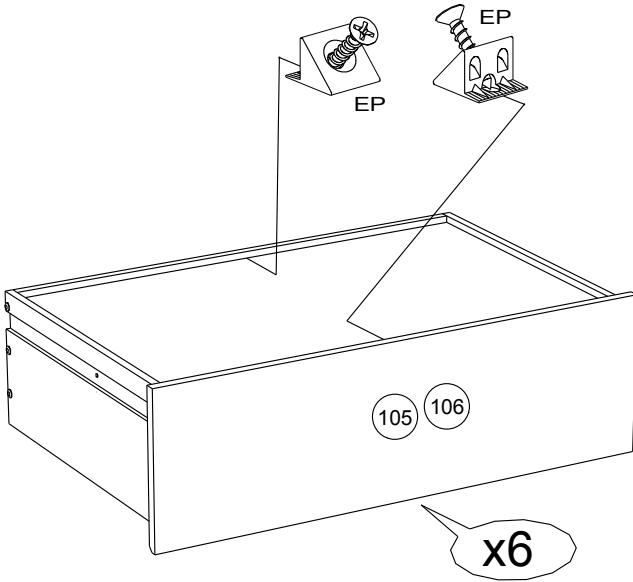

16

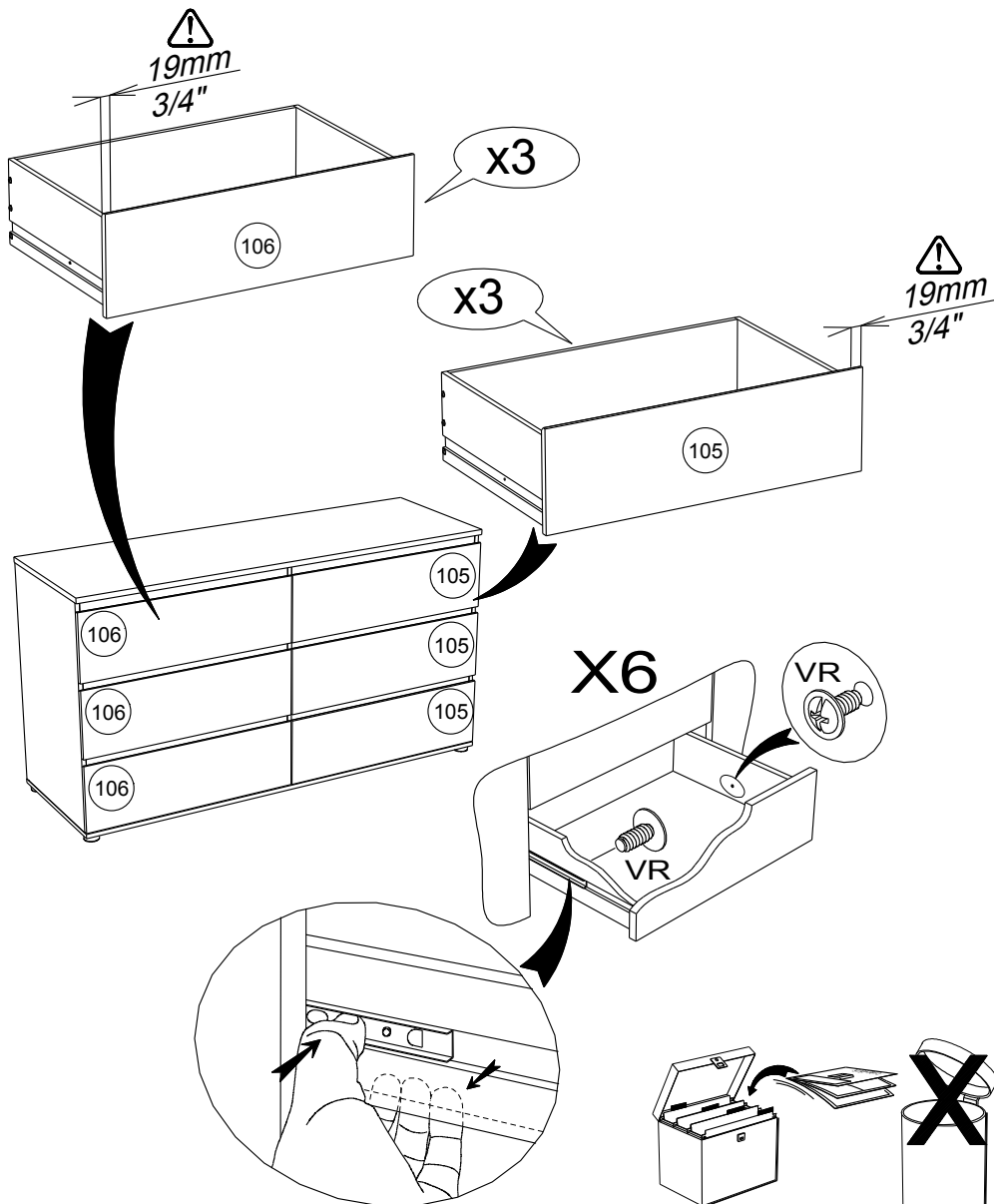

Faites un geste pour l'environnement en triant vos déchets d'emballage
 Make a gesture for the environment by sorting out your waste of packaging
 Machen Sie eine Bewegung für die Umwelt, ihre Verpackungsabfälle sortierend
 Haga un gesto para el medio ambiente escogiendo sus residuos de embalaje