

# LWD51

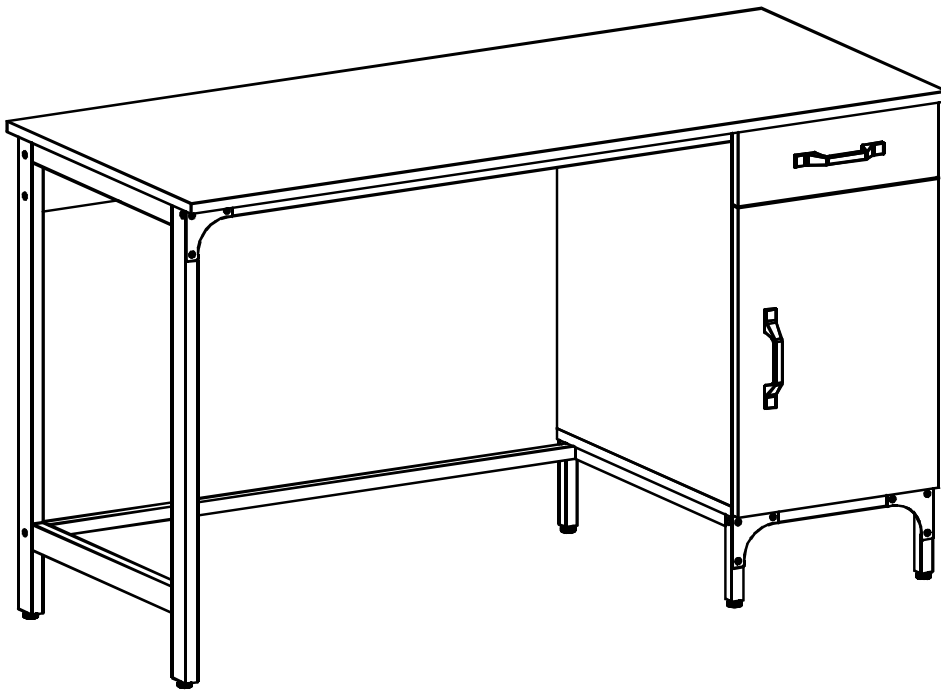

## General Guidelines

- Please read the following instruction carefully and use the product accordingly.
- Please keep this manual and hand it over when you transfer the product.
- This summary may not include every detail of all variations and considered steps. Please contact us when further information and help are needed.

## Notes

- The item is intended for household or office use only. It must be assembled and used in accordance with the provisions of the manual.
- Please refer to the diagram during assembly. Loosely tighten all the screws in their corresponding pre-drilled holes first, then fully tightening them. It is recommended that assembly is undertaken by at least 2 adults.
- Adjustable feet are designed to prevent scratches on the floor and keep stable on uneven floors.
- Avoid direct sun exposure to prevent surface damage and shorten its lifespan.
- For daily maintenance, please clean the product with a soft damp cloth, then wipe dry with a clean cloth. Do not wipe the surface with hard or abrasive objects.

## Warning

- During the assembly process, keep any small parts and packaging (films, plastic bags and foam etc.) out of the reach of children. It may be fatal if swallowed or inhaled.
- It is forbidden children to climb or play on the product to avoid serious body injury caused by the toppling.
- Never touch with sharp objects or corrosive chemicals, which may damage the surface of this item.
- If there are defective or missing parts, please do not use the product to avoid potential hazards.
- Periodically inspect to ensure screws are tightened while the product is in use. If necessary, retighten to ensure structural integrity and safety.
- The maximum load capacity is 50 kg (110 lb), do not place overweight items on it.

## Einleitung

- Bitte lesen Sie die folgende Anleitung aufmerksam durch und verwenden Sie das Produkt sachgemäß.
- Bewahren Sie diese Anleitung gut auf und händigen Sie sie bei Weitergabe des Produkts an Dritte ebenfalls mit aus.
- Aus Gründen der Übersicht können nicht alle Details zu allen Varianten und denkbaren Montagen beschrieben werden. Wenn Sie weitere Informationen und Hilfe benötigen, kontaktieren Sie uns bitte.

## Hinweise

- Dieses Produkt ist hauptsächlich für den Gebrauch zuhause oder im Büro bestimmt. Bauen Sie und benutzen Sie dieses Produkt bitte streng nach der Anleitung auf.
- Beim Zusammenbau beachten Sie bitte die im Bildteil dargestellten Montageschritte. Und ziehen Sie die Schrauben erst in der Endphase fest. Die Montage des Produktes geschieht am besten mit zwei Erwachsenen.
- Die verstellbaren Füße verhindern das Verrutschen und unerwünschte Kratzen am Boden.
- Um Beschädigungen des Produkts zu verhindern und eine längere Lebensdauer zu gewährleisten, sollte der Tisch vor direkter Sonneneinstrahlung geschützt werden.
- Zur täglichen Pflege benutzen Sie bitte ein weiches und leicht angefeuchtetes Tuch und wischen Sie danach die Oberfläche des Produkts sofort mit einem trockenen Tuch ab. Vermeiden Sie jeden Kontakt der Oberfläche mit harten oder zu nassen Gegenständen.

## Warnhinweise

- Halten Sie Kinder, besonders Säuglinge während der Montage vom Arbeitsbereich fern. Zum Lieferumfang gehört eine Vielzahl von Kleinigkeiten und als Verpackungsmaterial Plastikfolien. Diese können beim Verschlucken oder Inhalieren lebensgefährlich sein.
- Lassen Sie keine Kinder auf den Tisch klettern, um Verletzungen zu verhindern.
- Das Produkt darf nicht in Kontakt mit scharfen Gegenständen oder chemisch aggressiven Substanzen kommen, um die Beschädigung des Produkts zu vermeiden.
- Benutzen Sie das Produkt bitte NICHT, wenn Teile beschädigt sind oder fehlen, um eine Verletzungsgefahr zu vermeiden.
- Überprüfen Sie bitte regelmäßig den festen Sitz der Schrauben und Verbindungsteile, falls notwendig nachziehen!
- Die max. Belastbarkeit beträgt 50 kg, stellen Sie keine Gegenstände, die diese Schwelle überschreiten, auf das Produkt.

## Introduction

- Lisez attentivement ces instructions et utilisez votre produit d'après ce mode d'emploi.
- Conservez ces instructions. Si vous souhaitez offrir ce produit à un tiers, joignez obligatoirement ce mode d'emploi.
- Pour des raisons de clarté, les détails concernant chaque variante ou montage envisageable ne peuvent être tous décrits. Si vous souhaitez obtenir plus d'informations ou si vous rencontrez certains problèmes non traités de manière détaillée dans ces instructions, veuillez nous contacter.

## Notes

- Cette table d'ordinateur est conçue uniquement pour un usage à l'intérieur (dans les maisons ou dans les entreprises). Les utilisations qui ne correspondent pas à la description ci-dessus ou les transformations de l'article ne sont pas autorisées. Il doit être monté et utilisé d'après ce mode d'emploi.
- Veuillez d'abord positionner et régler les pièces en faisant référence à la notice de montage, puis effectuer un serrage progressif. L'assemblage de ce produit par deux adultes est conseillé.
- Les pieds réglables pour la mise à niveau sont conçus spécialement pour éviter les rayures au sol et le glissement accidentel.
- N'exposez pas la table d'ordinateur aux rayons forts du soleil, pour ne pas endommager la surface du produit et prolonger sa durée de vie.
- Il est conseillé de nettoyer la table avec un chiffon humide, puis de l'essuyer avec un chiffon sec. Évitez de nettoyer avec un chiffon trop mouillé et des objets abrasifs.

## Avertissements

- Ne laissez pas les enfants jouer dans la zone de travail lors du montage et des ajustages. L'inhalation et l'avalage de pièces ont un risque mortel. Gardez les sacs plastiques hors de la portée des bébés et des enfants.
- Il est interdit aux enfants de monter sur le produit, afin d'éviter des accidents.
- Évitez tout contact avec des objets pointus et des produits chimiques corrosifs afin de ne pas endommager la surface du produit.
- Le produit abîmé ne doit en aucun cas être utilisé.
- Il est conseillé de vérifier régulièrement le serrage des vis afin d'éviter des dangers cachés.
- La charge maximale du produit est de 50 kg, ne dépassez pas cette limite.

IT

## Linee guida generali

- Si prega di leggere attentamente le seguenti istruzioni, e raccomandiamo di utilizzare questo prodotto in conformità allo scopo.
- Si prega di conservare questo manuale, quando il prodotto viene consegnato ad una terza persona si prega di consegnarle anche questo manuale.
- Questo manuale non può includere tutti i dettagli di tutte le variazioni e le fasi considerate. Contattateci quando sono necessarie ulteriori informazioni e aiuto.

## Note

- Il prodotto è stato progettato per uso in casa o in ufficio come tavolo da computer. Si prega di seguire attentamente le istruzioni di montaggio e usare il prodotto solo nelle applicazioni previste.
- Durante il montaggio non stringere completamente le viti fino alla fase finale. Consigliamo di completare il montaggio in due adulti.
- I piedini regolabili sono progettati per evitare che il tavolo scivoli e graffi il pavimento.
- Evitare l'esposizione diretta al sole per prevenire danni superficiali e riduzione della vita utile.
- Per la manutenzione quotidiana, pulire il prodotto con un panno umido morbido, quindi pulirlo con un panno asciutto. Non pulire la superficie con oggetti duri o abrasivi.

## Avvertenze

- Durante la fase di montaggio, si raccomanda di tenere i bambini a debita distanza, in quanto alcune parti di piccole dimensioni, come le viti, potrebbero essere ingoiate con conseguenze dannose per la salute.
- Ai bambini non è consentito salire o giocare intorno al prodotto per evitare lesioni.
- Non lasciare il prodotto a contatto con oggetti taglienti o prodotti chimici corrosivi per evitare danni al prodotto.
- Si prega di interrompere immediatamente l'uso nel caso in cui si notino parti difettose e/o mancanti, altrimenti c'è il rischio di ferirsi.
- Si prega di controllare periodicamente la resistenza di tutte le viti e delle connessioni per la sicurezza e per evitare danni imprevisti.
- Il carico massimo del prodotto è di 50 kg, non collocare oggetti che superano questa soglia sul prodotto.

ES

## Acerca del manual

- Por favor, lea detenidamente las instrucciones y respete los debidos usos del producto.
- Por favor, conserve bien este manual y en caso de cesión, no omita entregarlo junto al producto.
- Este manual podría no incluir todos los detalles de cada paso del montaje. Si necesita ayuda o información adicional, póngase en contacto con nosotros.







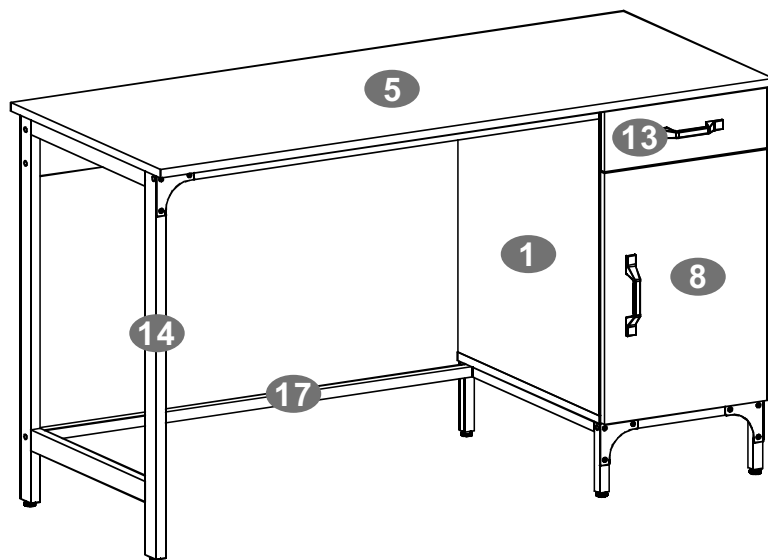

## Notas

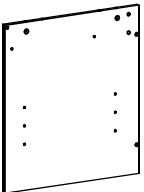
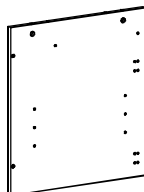
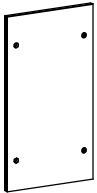
- El producto está diseñado para uso doméstico o de oficina como una mesa de ordenador. Monte y utilice el producto siguiendo estrictamente paso a paso las instrucciones.
- Hay que seguir las ilustraciones para poner y ajustar las piezas. No apriete completamente los tornillos hasta que complete todas las piezas. Se recomienda realizar el montaje entre dos adultos.
- Las patas regulables están en la parte inferior para proteger el suelo de los rayones y prevenir el resbalón de la mesa.
- No deje la mesa expuesta al sol para evitar dañar a la mesa y reducir la vida útil.
- No limpie la superficie con los objetos duros o un trapo mojado, sino con una toalla húmeda, luego séquela con un paño o una toalla seca.

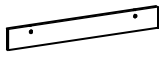

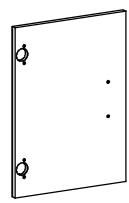





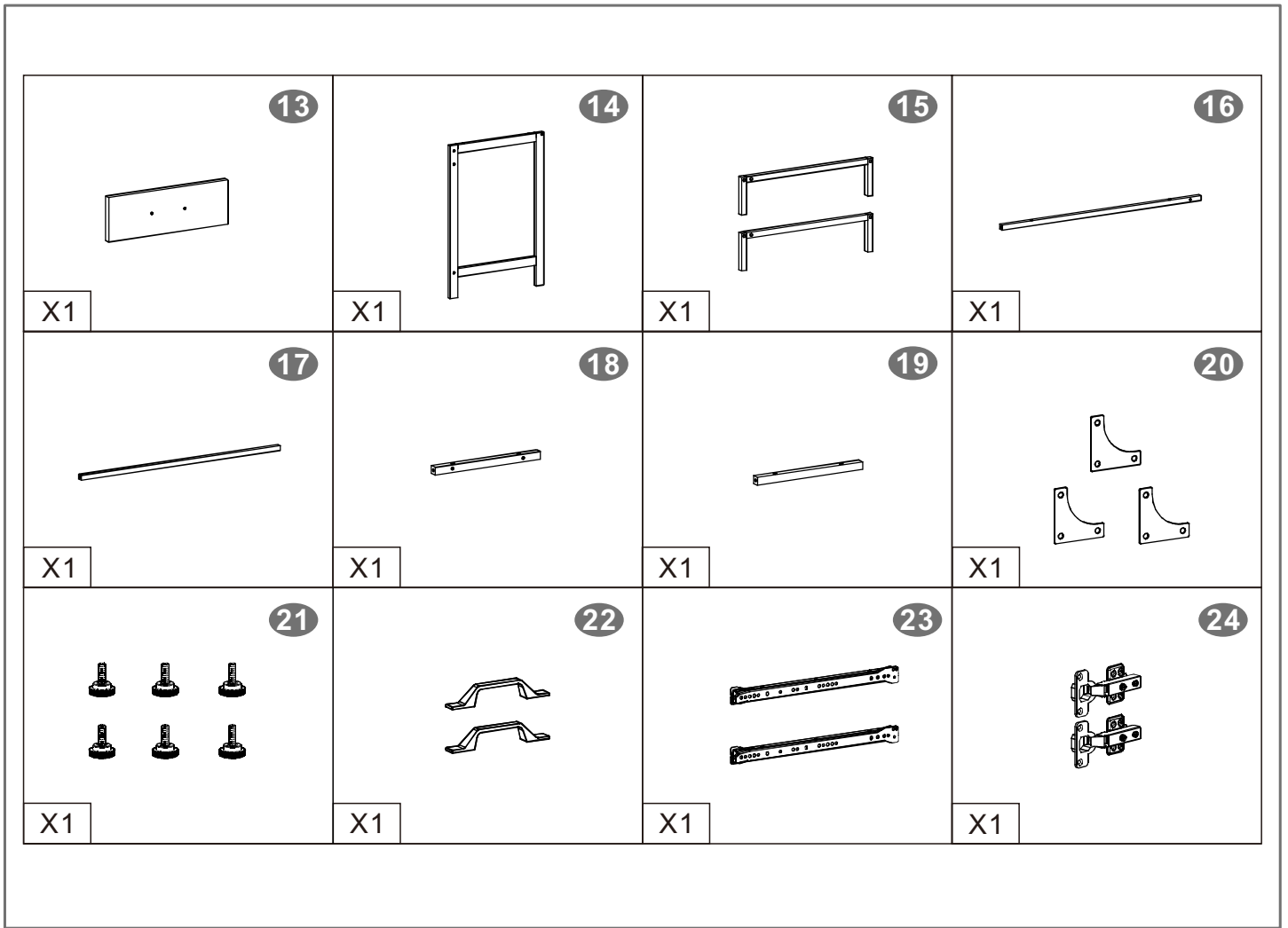



## Advertencias

- Mantenga alejados a los niños de las piezas y de la bolsa de plástico para evitar las lesiones por tragar por algo.
- No permita que los niños se suban y jueguen con el producto para prevenir los daños.
- Mantenga el producto alejado de los objetos afilados y productos químicos para evitar dañar el producto.
- No use el producto cuando se encuentre las piezas defectuosas o faltantes, de lo contrario, existirá el riesgo de lesiones.
- Compruebe regularmente todos los tornillos y conexiones para garantizar la seguridad.
- Puede soportar el peso máximo de 50 kg, no coloque los objetos demasiado pesados.



<p>1</p>  <p>X1</p>	<p>2</p>  <p>X1</p>	<p>3</p>  <p>X1</p>	<p>4</p>  <p>X1</p>
<p>5</p>  <p>X1</p>	<p>6</p>  <p>X1</p>	<p>7</p>  <p>X1</p>	<p>8</p>  <p>X1</p>
<p>9</p>  <p>X1</p>	<p>10</p>  <p>X1</p>	<p>11</p>  <p>X1</p>	<p>12</p>  <p>X1</p>

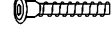

<b>A</b>	14	6X40 MM		<b>H</b>	12	4X16 MM	
<b>B</b>	8	8X40 MM		<b>I</b>	10	4X12 MM	
<b>C</b>	8	6X35 MM		<b>J</b>	4	Φ5 MM	
<b>D</b>	6	6X30 MM		<b>K</b>	2	6X50 MM	
<b>E</b>	9	6X8 MM			1		
<b>F</b>	12	7X50 MM			1		
<b>G</b>	4	4X20 MM					

## ■ 6×40MM Wooden Bolt Installation As Below:

	<b>Bolt</b>	<b>Bolzen</b>
	<b>Boulon</b>	<b>Bullone</b>
	<b>Perno</b>	

---

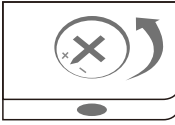
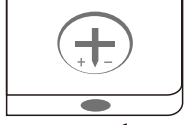

Connecting piece  
Verbindungsbeschlag  
Pièce de raccord  
Pezzo di bloccaggio  
Pieza de sujeción

 <p><b>X</b></p>	 <p><b>✓</b></p>
<p>Adjust connecting piece direction if condition as illustrated</p> <p>Stellen Sie die Richtung des Verbindungsbeschlags ein, falls der Zustand wie dargestellt</p> <p>Ajustez l'écrou selon le schéma</p> <p>Regolare la direzione di pezzo di collegamento come la condizione illustrata</p> <p>Ajustar la pieza de sujeción según la dirección ilustrada</p>	<p>Insert bolt when connecting piece under such condition</p> <p>Stecken Sie den Bolzen in diesem Zustand ein</p> <p>Insérez le boulon quand la pièce de raccord est dans telle condition</p> <p>Inserire il bullone quando il pezzo di collegamento è in tale condizione</p> <p>Insertar el perno cuando se encuentre así la pieza de sujeción</p>

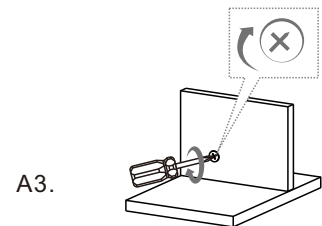
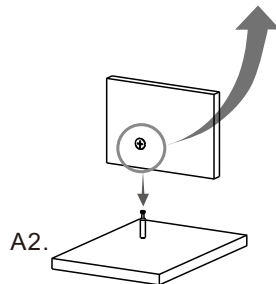
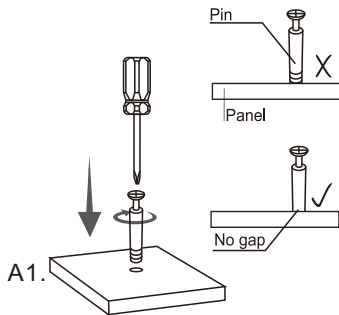



## Tips/Hinweise/Notes/Suggerimenti/Sugerencias



- EN•** If there is any damage after unpacking or you have any questions during assembly, please feel free to contact us at your earliest convenience. Our customer care team provides professional returns or exchanges as well as assembly guidance.
- DE•** Wenn das Produkt nach dem Auspacken Schäden aufweist oder Sie bei der Montage Fragen haben, fühlen Sie sich frei, sich an uns zu wenden. Unser Kundenservice nimmt professionelle Dienstleistungen wie Retouren, Umtausche und Montageberatungen vor.
- FR•** Si le produit reçu est endommagé et vous voulez le retourner ou l'échanger. Ou si vous avez des questions pendant le montage, n'hésitez pas à nous contacter. Notre équipe de service à la clientèle vous répond dans un plus bref délai.
- IT•** In caso di danni dopo il disimballaggio o eventuali domande durante l'assemblaggio, non esitare a contattarci al più presto. Il nostro team di assistenza clienti fornisce resi o sostituzioni professionali e guida all'assemblaggio.
- ES•** Si hay algún daño después de desembalar o si tiene alguna pregunta durante el montaje, no dude en ponerse en contacto con nosotros. Nuestro equipo de atención al cliente proporciona servicios de devoluciones o cambios profesionales, así como orientación para el montaje.



1

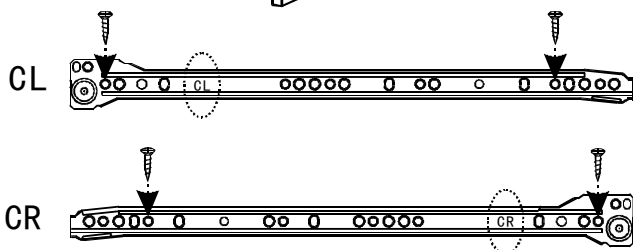
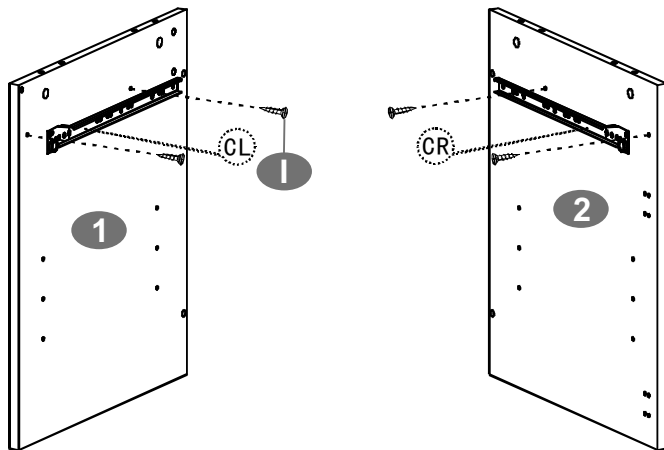

CL and CR are stencil printed on the guide rail.



**I** 4X12 MM  x4 

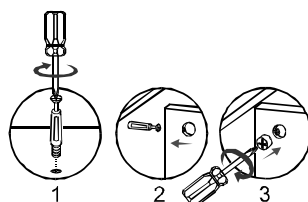
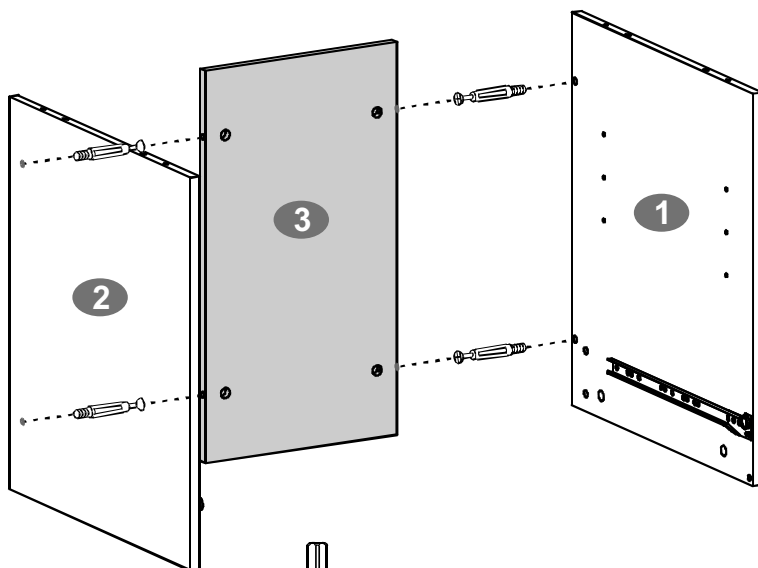

2



**A** 6X40 MM   x4 

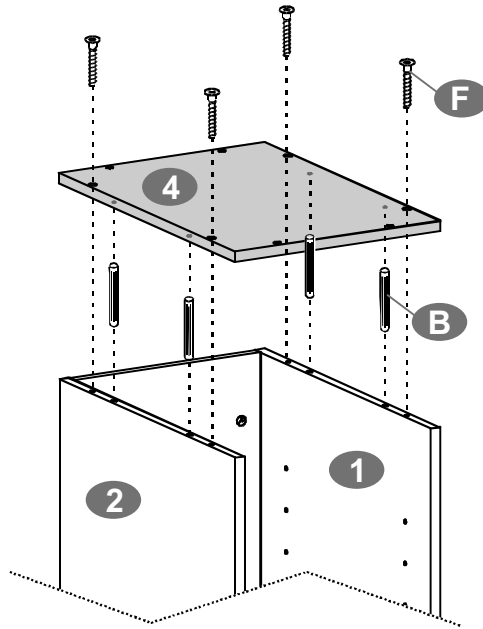

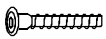
3

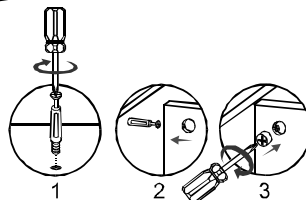
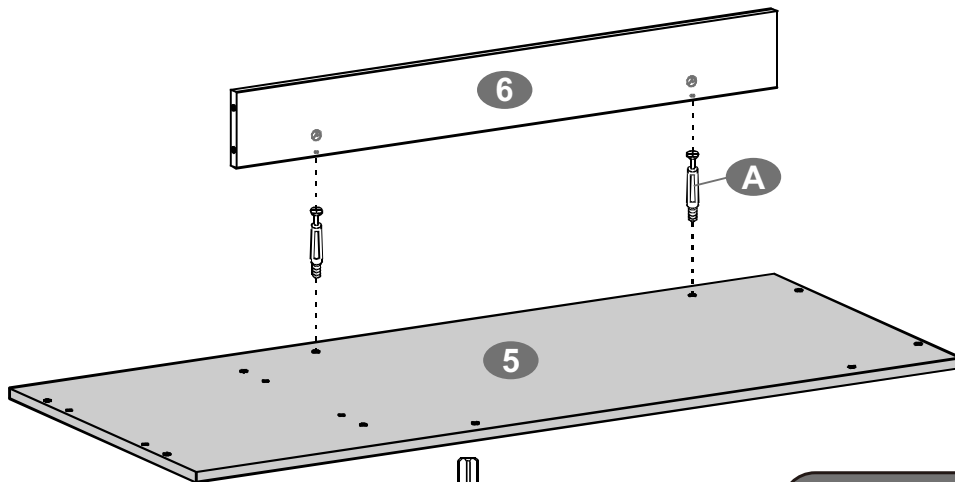

<b>F</b>	7X50 MM		x4	
<b>B</b>	8X40 MM		x4	

4



<b>A</b>	6X40 MM		x2	
----------	---------	---	----	---

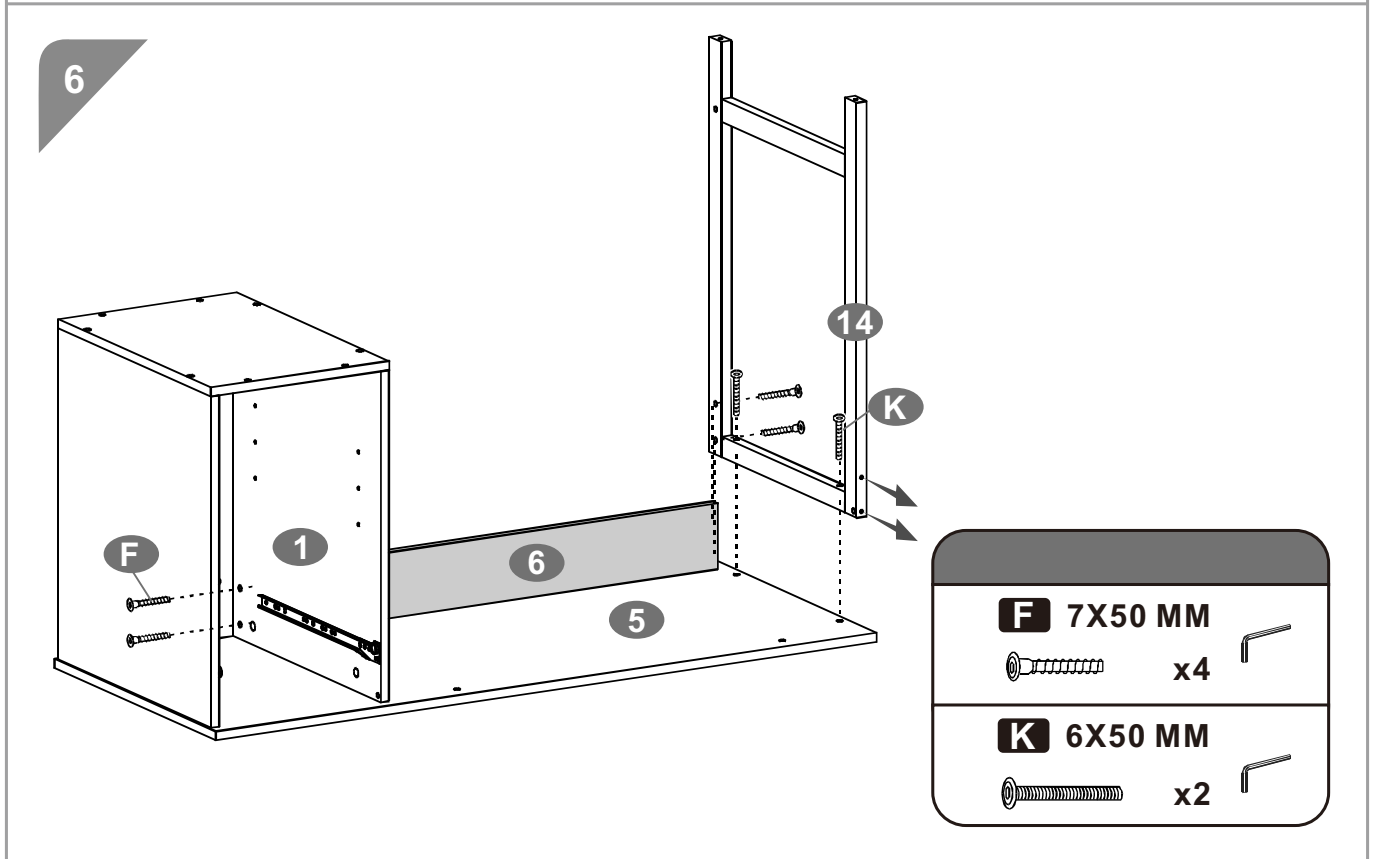
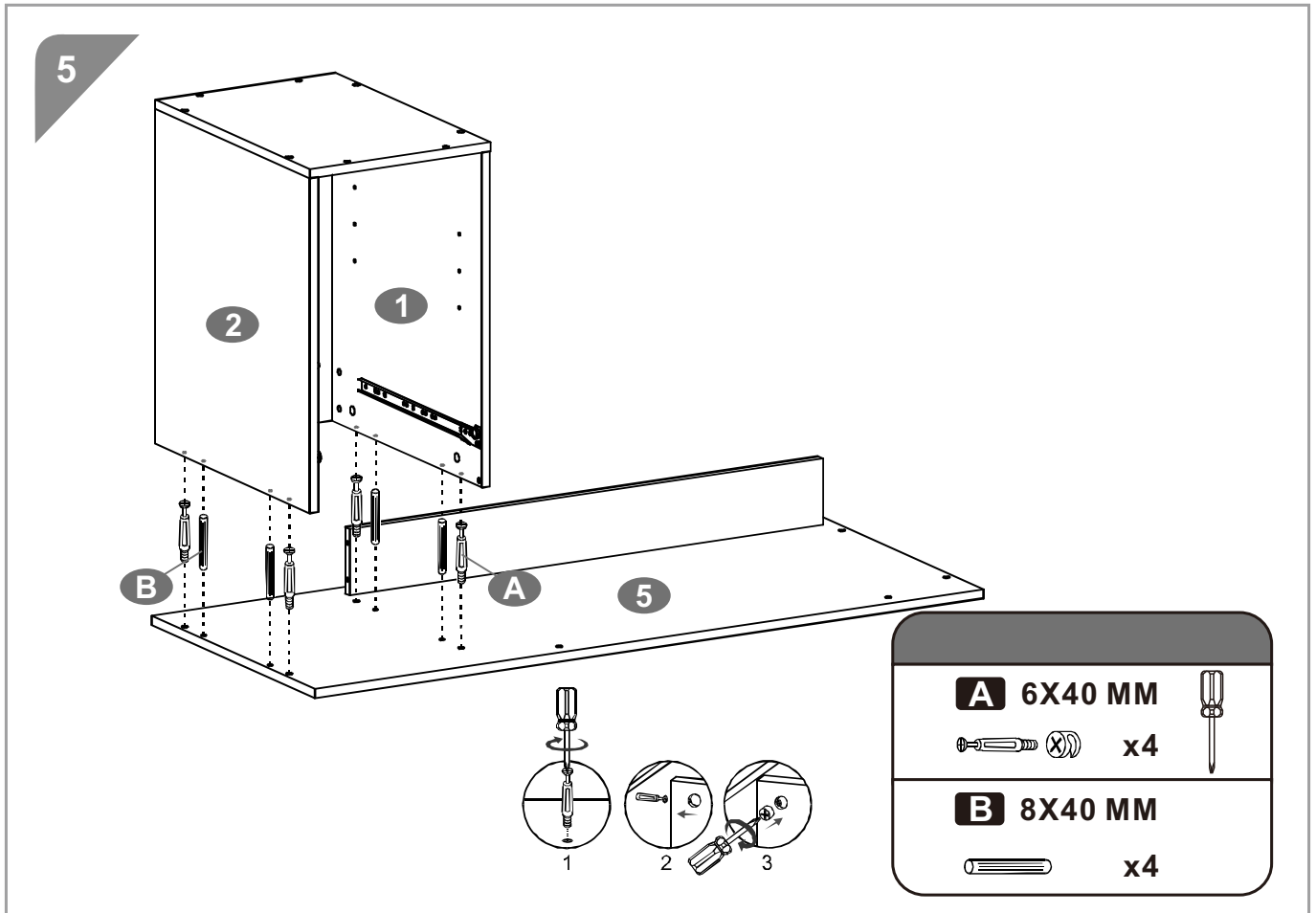

7

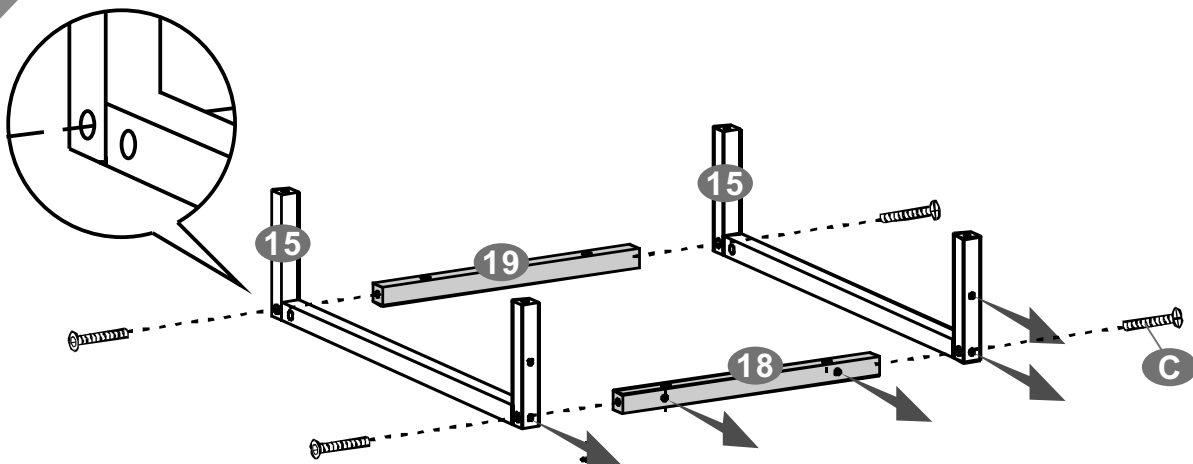

**C** 6X35 MM

 x4 

8

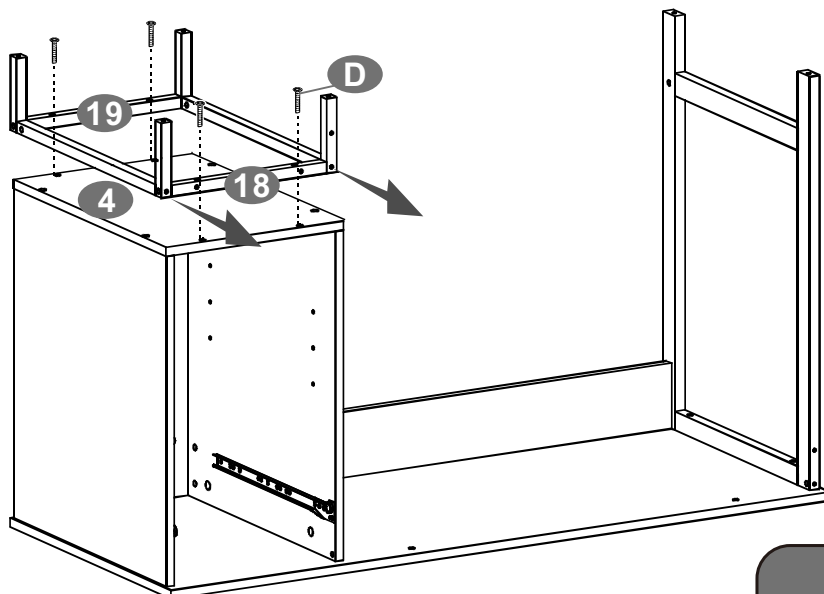

**D** 6X30 MM

 x4 

9

During assembly, align the bolts loosely first, and then tighten all the bolts firmly after all the bolts are aligned. The diameter of the holes on the pipes is 2-3 mm larger than that of bolts, so the position of the fittings can be slightly adjusted if necessary.

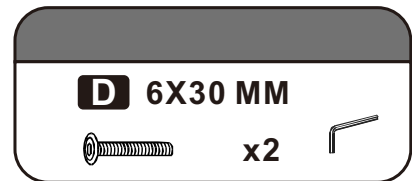
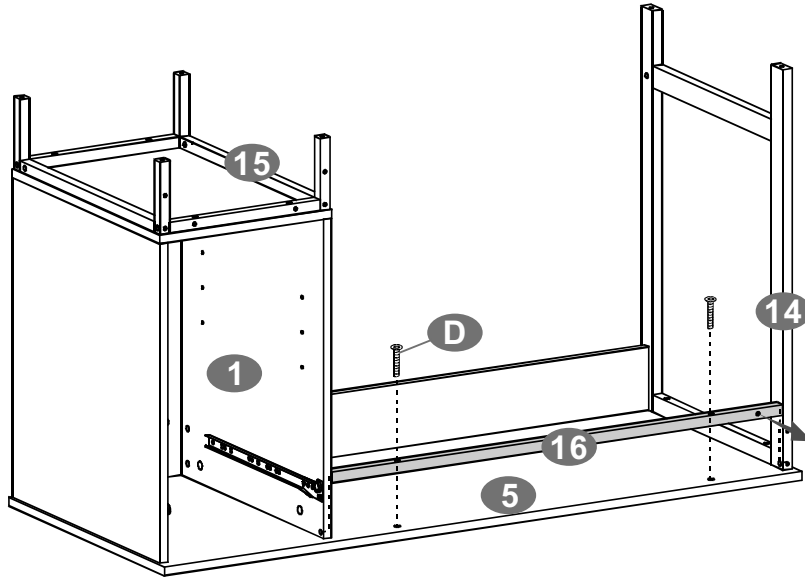

10

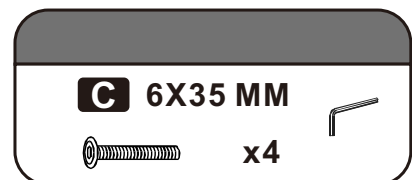
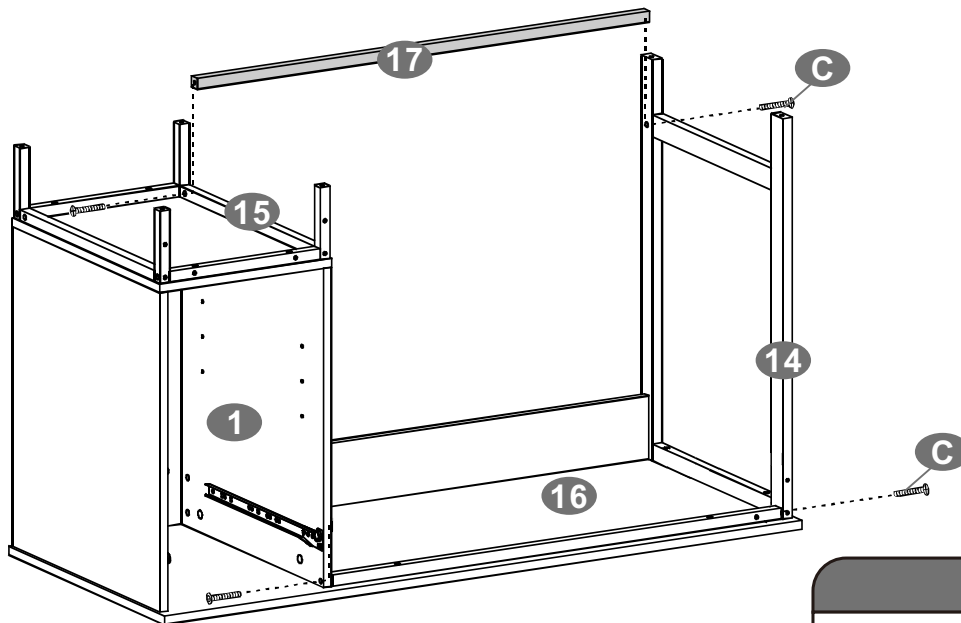

11

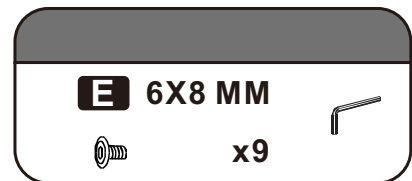
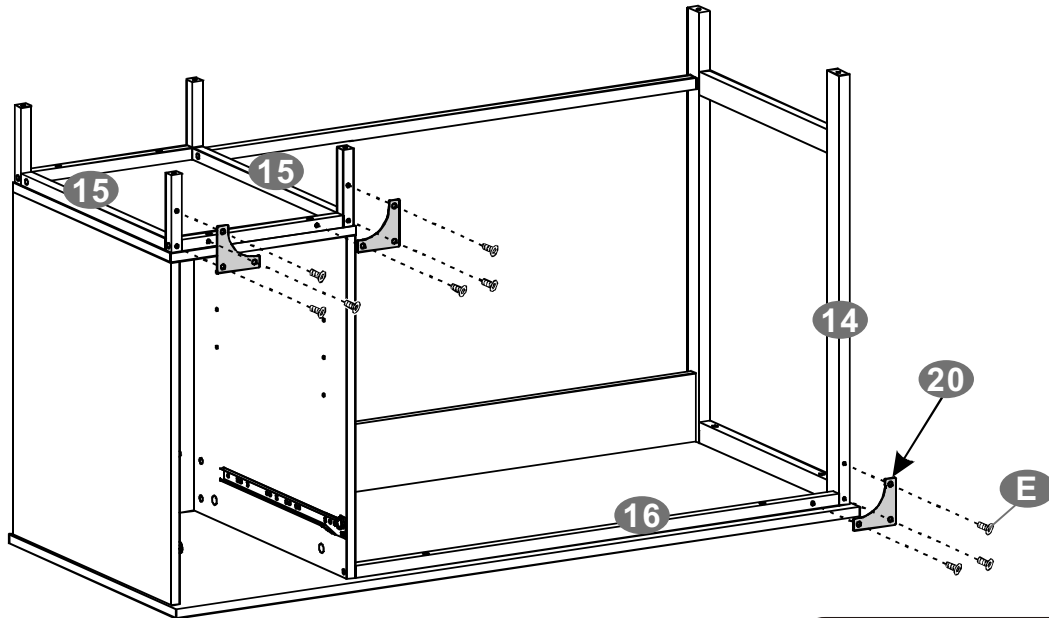

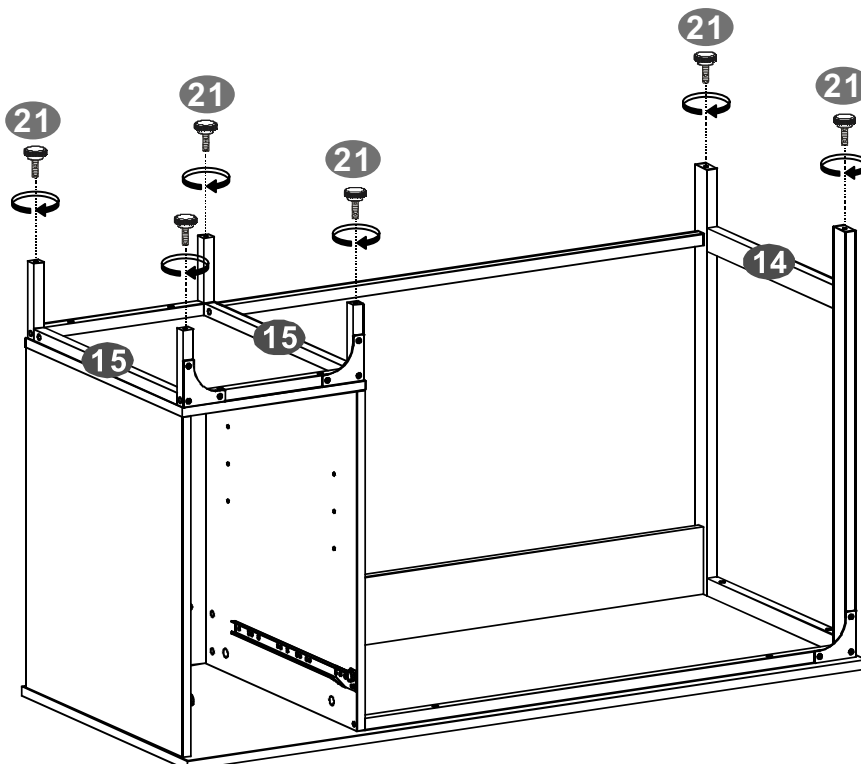

12

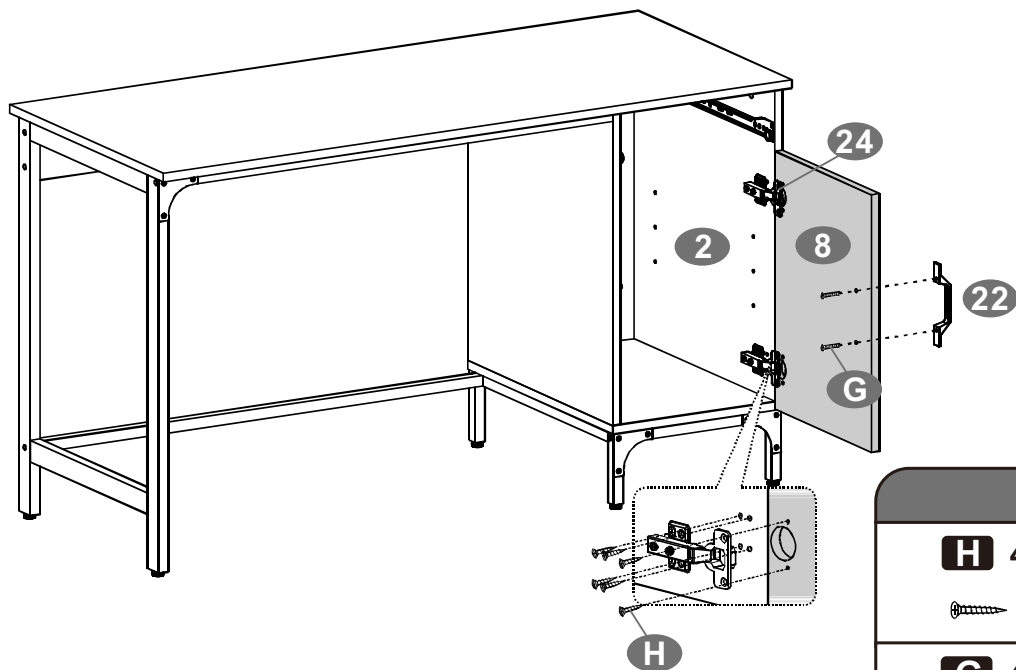

13



<b>H</b>	4X16 MM	
	x12	
<b>G</b>	4X20 MM	
	x2	

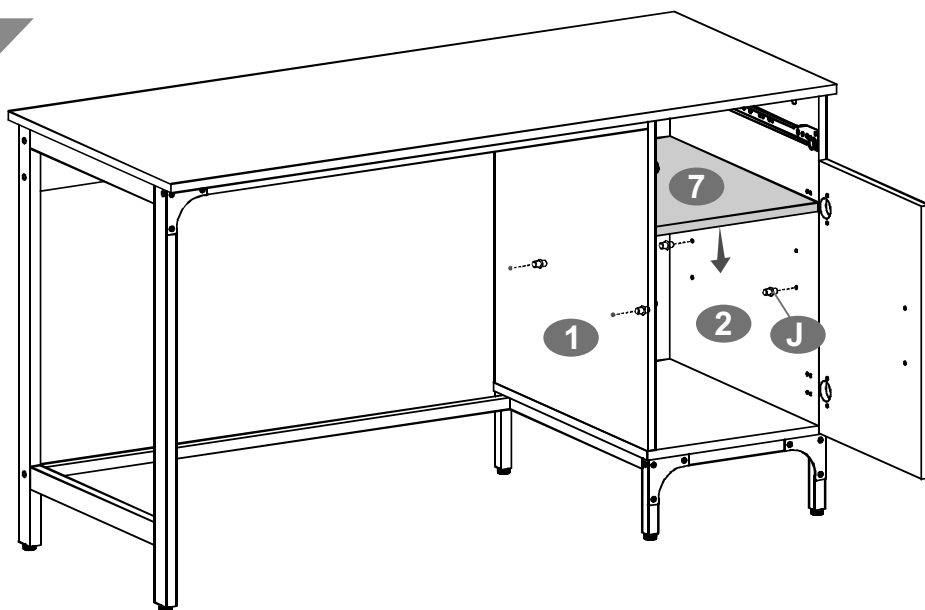

14

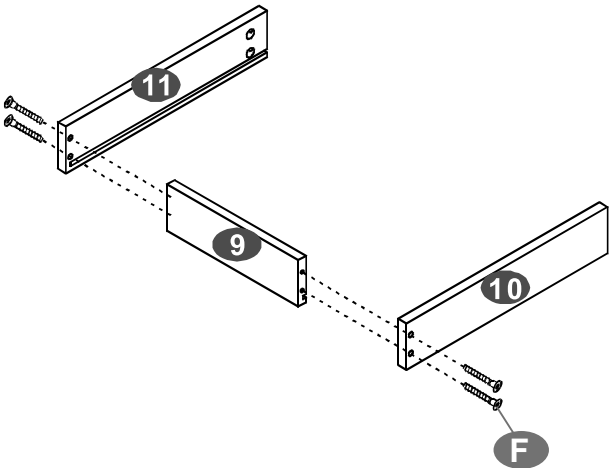

<b>J</b>	Φ 5 MM	
	x4	

15

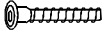

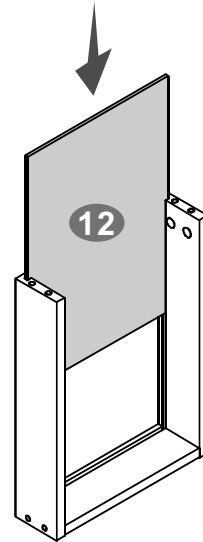

**F** 7X50 MM  
 x4 

16



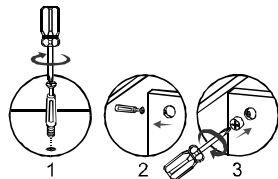
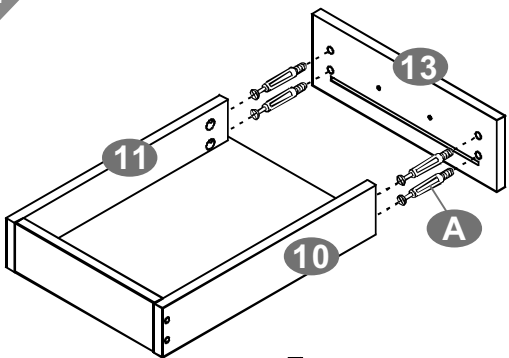

17

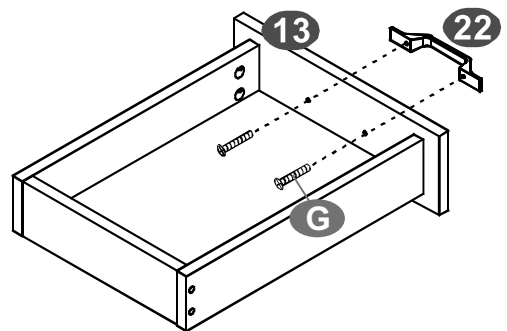

**A** 6X40 MM  
 (X) x4 

18



**G** 4X20 MM  
 x2 



19

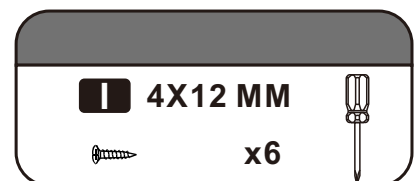
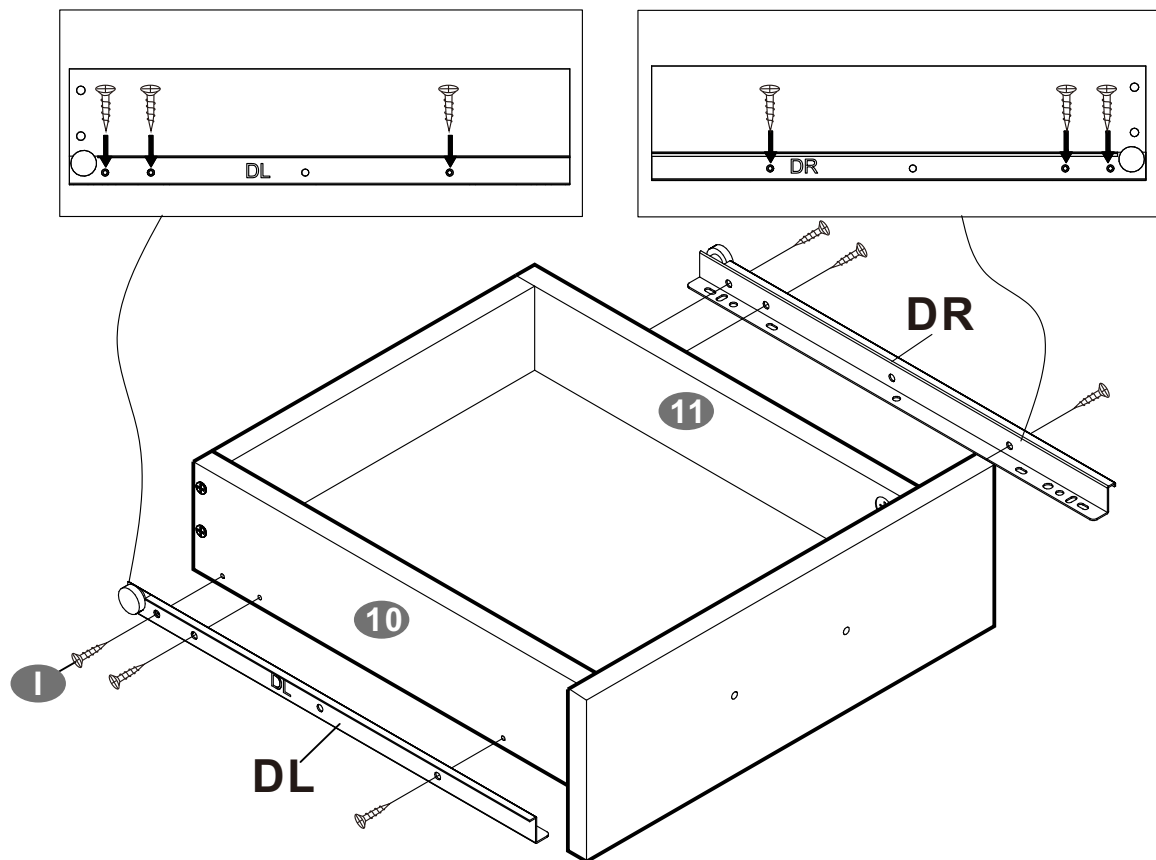

20

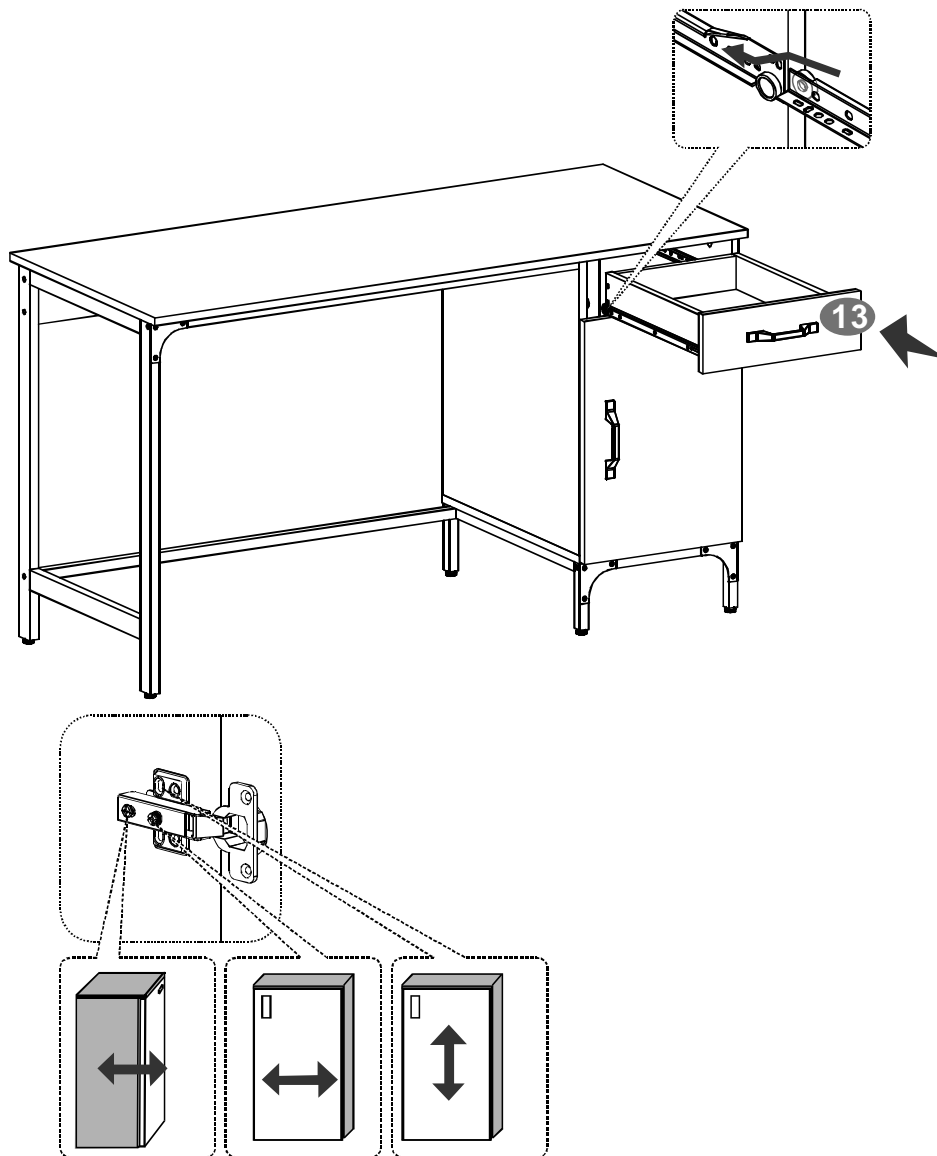

- EN** • By tightening these two screws, you can adjust the position of the front, back, left, and right of the board so that the board is in a proper position.
- DE** • Serrez plus ou moins ces 2 vis, vous pouvez ajuster la position de l'avant, de l'arrière, de la gauche et de la droite de la planche afin que la planche soit dans une position correcte.
- FR** • Puede ajustar la posición de la parte delantera, trasera, izquierda y derecha del tablero apretando estos dos tornillos para que el tablero esté en una posición adecuada.
- IT** • Serrando queste due viti, è possibile regolare la posizione della parte anteriore, posteriore, sinistra e destra della scheda in modo che la scheda sia in una posizione corretta.
- ES** • Indem Sie an diesen beiden Schrauben drehen, können Sie die Türplatte nach vorne, hinten, links und rechts verschieben und die richtige Position einstellen.

## Possible issues during assembly:

- Holes on the boards and poles are not aligned, so screws can't be installed.

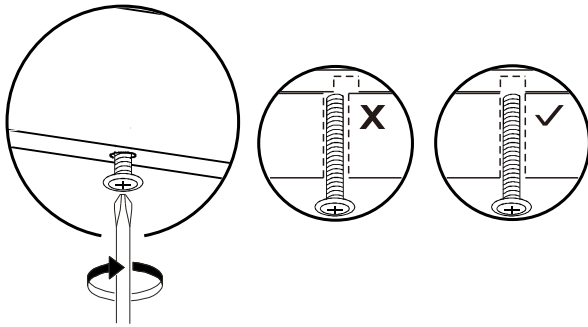

- Please slightly loosen all screws and adjust the boards. Because the diameter of the holes on the pipes is 2-3 mm larger than that of bolts, the position of the boards can be adjusted.
- If it still doesn't work after adjustment, please contact us for more solutions.