

20480C

3304CHES

PARISOT INDUSTRIE 70800 SAINT LOUP SUR SEMOUSE -FRANCE-

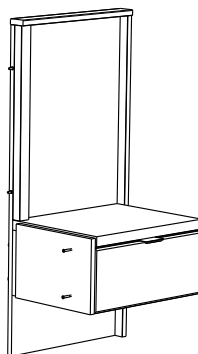
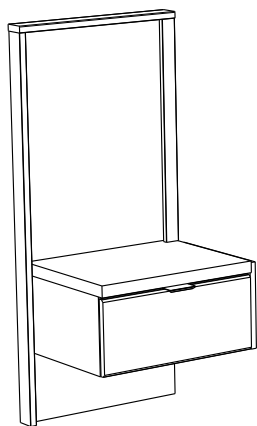

Gamme : TORONTO



PARISOT INDUSTRIE

FR Remerciements :

Nous vous remercions d'avoir choisi un meuble créé et fabriqué par le Groupe Parisot et espérons qu'il vous donnera entière satisfaction.

EN Thanks:

Thank you for choosing furniture designed and manufactured by the Parisot Group. We hope you are totally satisfied with your purchase.

DE Danksagung:

Wir danken Ihnen für den Kauf eines Frankreich von der Parisot-Gruppe entworfenen und hergestellten Möbelstücks und hoffen, dass Sie es zu Ihrer vollkommenen Zufriedenheit finden werden.

HU Köszönet:

Köszönjük, hogy a Parisot Groupe által létrehozott és gyártott bútort választott, reméljük, hogy elégedett lesz a termékkel.

PT Agradecimentos:

Obrigado por aver escolhido um móvel concebido e fabricado pelo Grupo Parisot, esperando que seja do seu inteiro agrado.

IT Ringraziamenti:

Grazie per avere scelto un mobile progettato e fabbricato dal Gruppo Parisot. Speriamo soddisfisi appieno le vostre esigenze.

NL Bedankje:

Wij bedanken u voor de aankoop van een door de Groep Parisot ontworpen en vervaardigd meubel en hopen dat u er veel plezier aan zult beleven.

CZ Poděkování:

Děkujeme, že jste si vybrali nábytek navržený a vyrobený společností Parisot Group. Doufáme, že budete svým nákupem naprosto spokojeni.

ES Agradecimientos:

Les damos las gracias por haber elegido un mueble diseñado y fabricado por el Groupe Parisot y esperamos que sea de su total agrado.

PL Podziękowania:

Dziękujemy za wybór mebli stworzonych i wyprodukowanych przez Grupę Parisot. Mamy nadzieję, że będziecie Państwo w pełni zadowoleni z zakupu.

RO Mulțumiri:

Vă mulțumim că ați ales un articol de mobilier conceput și fabricat de Grupul Parisot și sperăm că veți fi pe deplin satisfăcuți de acesta.

RU Благодарность:

Мы благодарим вас за то, что вы выбрали мебель, созданную и произведенную Групп Паризо, и надеемся,

что вы будете полностью удовлетворены нашей продукцией.

SK Pod'akovanie:

Ďakujeme, že ste si vybrali nábytok navrhnutý a vyrobený spoločnosťou Parisot Group. Dúfame, že budete svojim nákupom absolútne spokojní.

SL Hvala:

Hvala, ker ste izbrali pohištvo, ki je dizajnirano in proizvedeno s strani Parisot Group. Upamo, da ste maksimalno zadovoljni z vašim nakupom.

TR Teşekkür ederiz:

Parisot Group tarafından tasarlanan ve üretilen bu mobilyayı seçtiğiniz için teşekkür ederiz. Ürünümüzden memnun kalmanızı ümit ederiz.

ZH 感谢 :

感谢您选择帕里索集团设计制造的家具。我们希望您对此次购买十分满意、

AR شكر :

نشكركم لاختياركم هذه القطعة من الأثاث من تصميم وتصنيع مجموعة باريزو Parisot ونتمنى أن تتلوا رضاءكم.

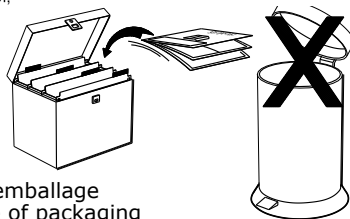

Faites un geste pour l'environnement en triant vos déchets d'emballage
Make a gesture for the environment by sorting out your waste of packaging
Machen Sie eine Bewegung für die Umwelt, ihre Verpackungsabfälle sortierend
Haga un gesto para el medio ambiente escogiendo sus residuos de embalaje
Pensate all'ambiente riciclando i vostri rifiuti di imballaggio
Naredite uslugo okolju in lo ujte odpadke

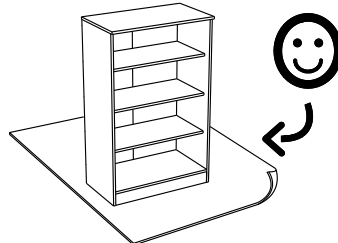
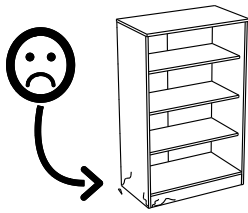
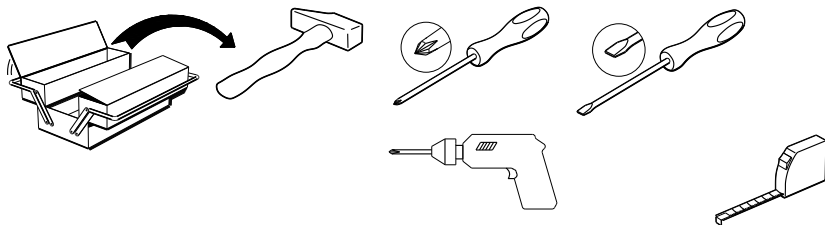

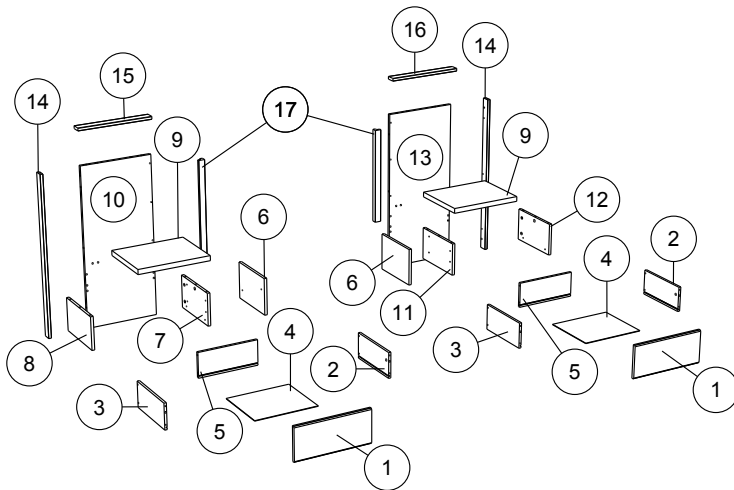
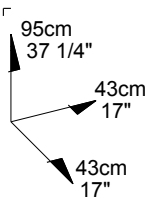

		mm			inch		
⑥	x 2	293	208	15	11 9/16	8 3/16	9/16
⑦	x 1	312	185	15	12 5/16	7 5/16	9/16
⑧	x 1	312	185	15	12 5/16	7 5/16	9/16
⑪	x 1	312	185	15	12 5/16	7 5/16	9/16
⑫	x 1	312	185	15	12 5/16	7 5/16	9/16
①	x 2	407	180	15	16	7 1/16	9/16
⑨	x 2	411	328	28	16 3/16	12 15/16	1 1/8
⑮	x 1	427	50	16	16 13/16	1 15/16	5/8
⑯	x 1	427	50	16	16 13/16	1 15/16	5/8
⑰	x 2	542	35	28	21 5/16	1 3/8	1 1/8
⑭	x 2	930	47	16	36 5/8	1 7/8	5/8
⑩	x 1	930	411	15	36 5/8	16 3/16	9/16
⑬	x 1	930	411	15	36 5/8	16 3/16	9/16
②	x 2	300	138	13	11 13/16	5 7/16	1/2
③	x 2	300	138	13	11 13/16	5 7/16	1/2
⑤	x 2	331	138	13	13 1/16	5 7/16	1/2
④	x 2	343	299	3	13 1/2	11 3/4	1/8

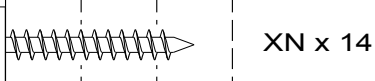
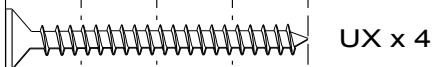
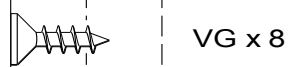
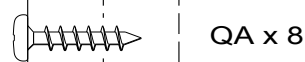
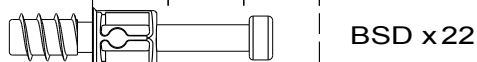
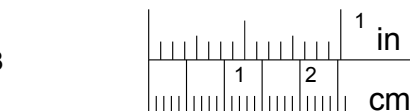
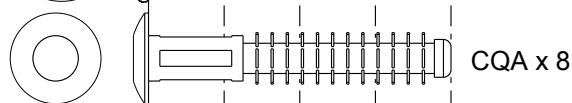
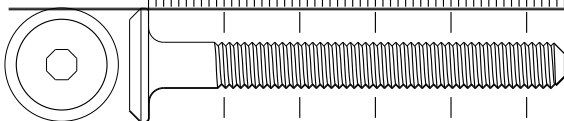
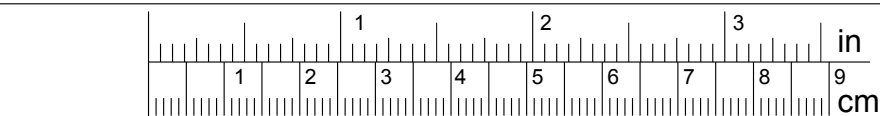
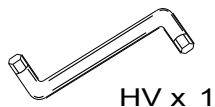
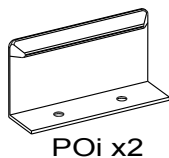
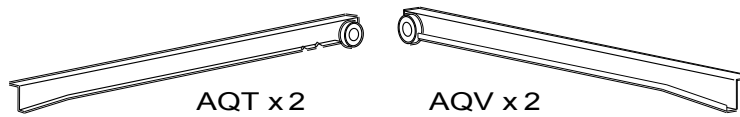
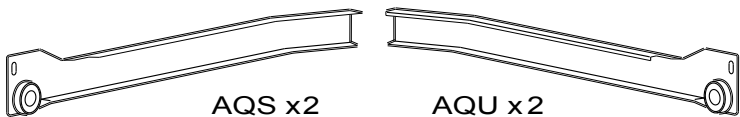

1

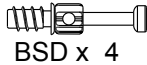

BSD x 4



ADU x 8

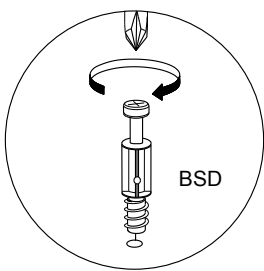

BSD

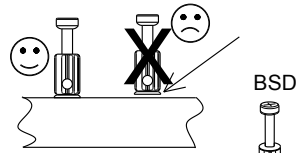

BSD

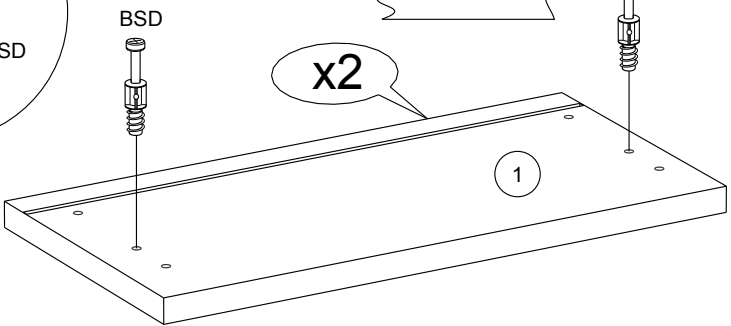

x2

1

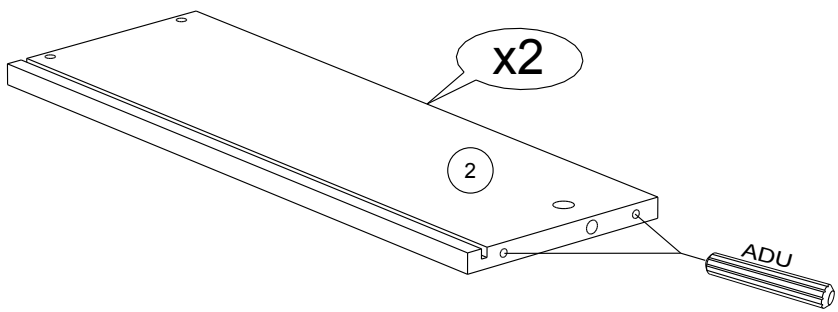

x2

2

ADU

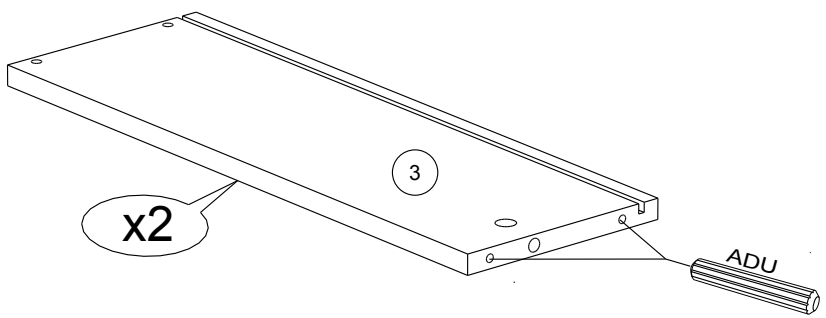

x2

3

ADU

2



BZG x 4



CQA x 8

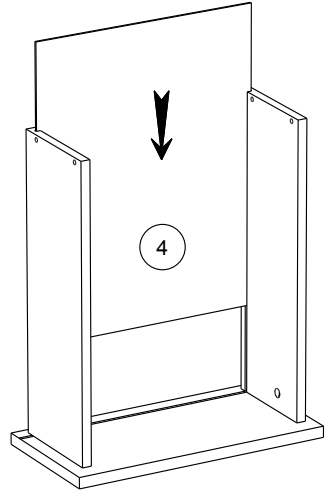
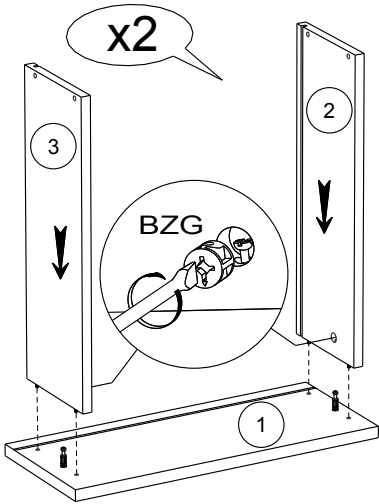

x2

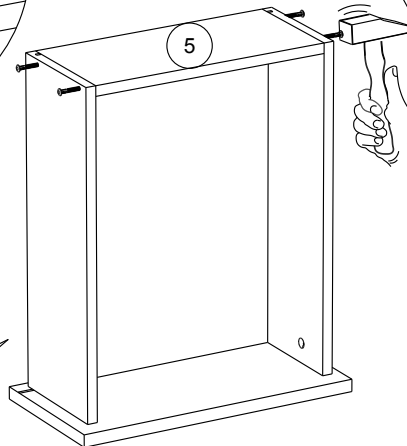
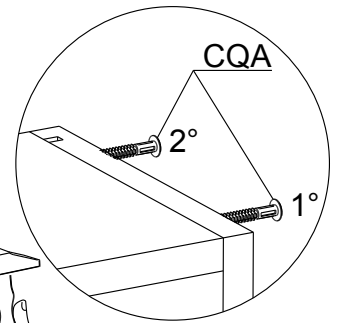
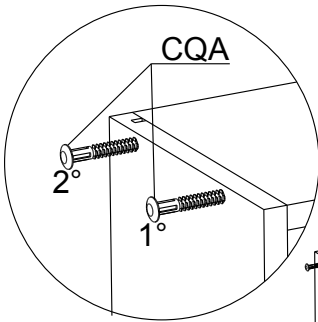

x2

3 ANK x 4

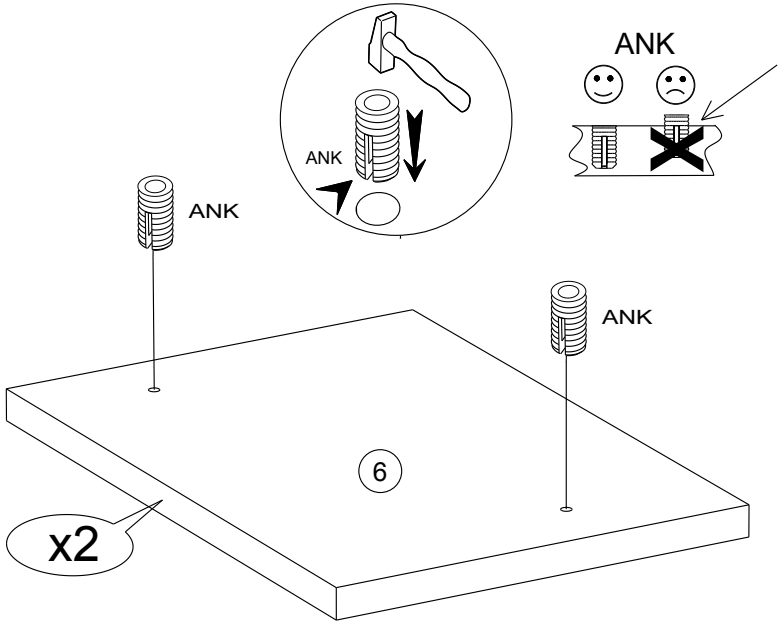

4 BSD x 4 ADM x 4 AHX x 4

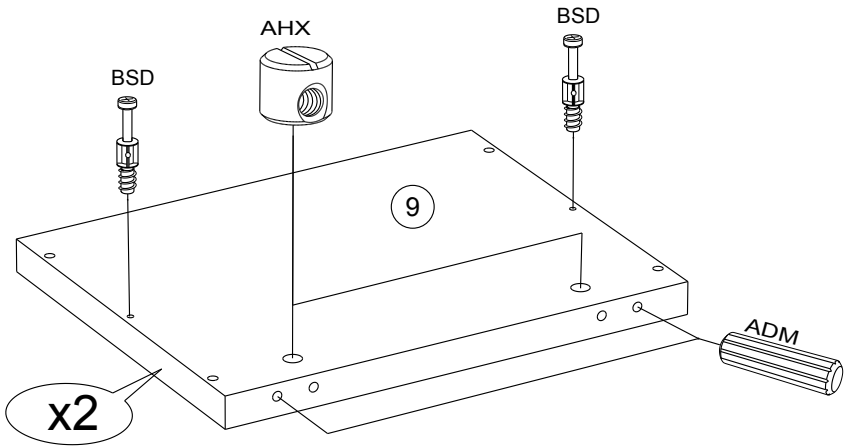

5

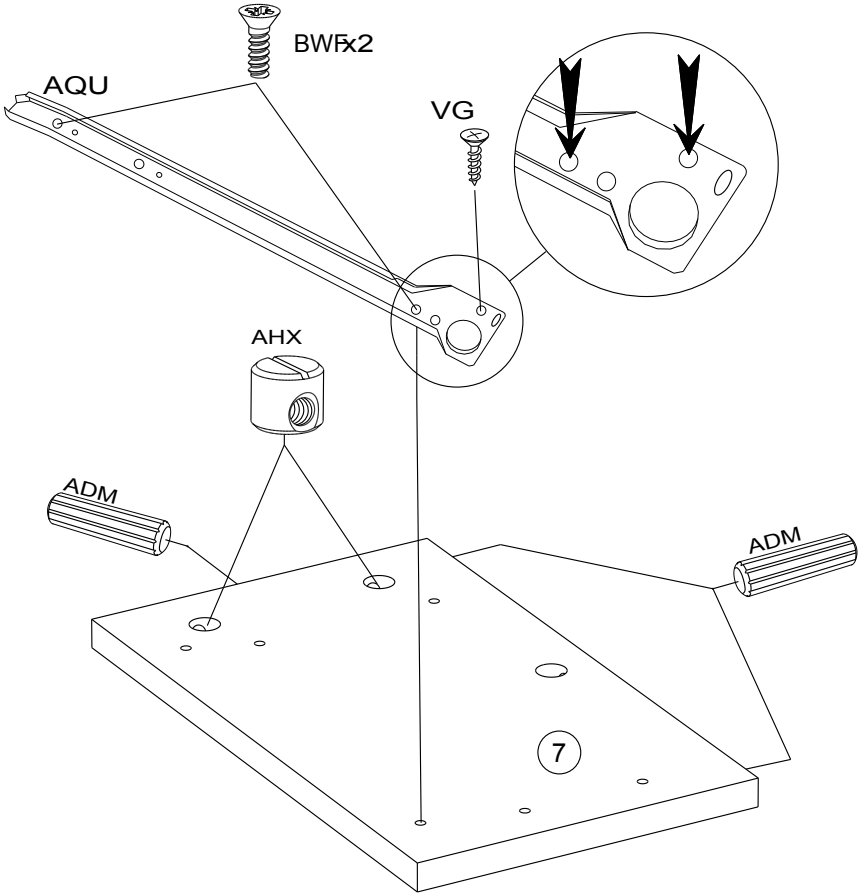
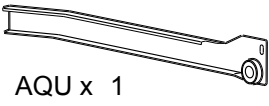

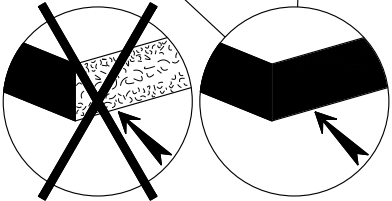
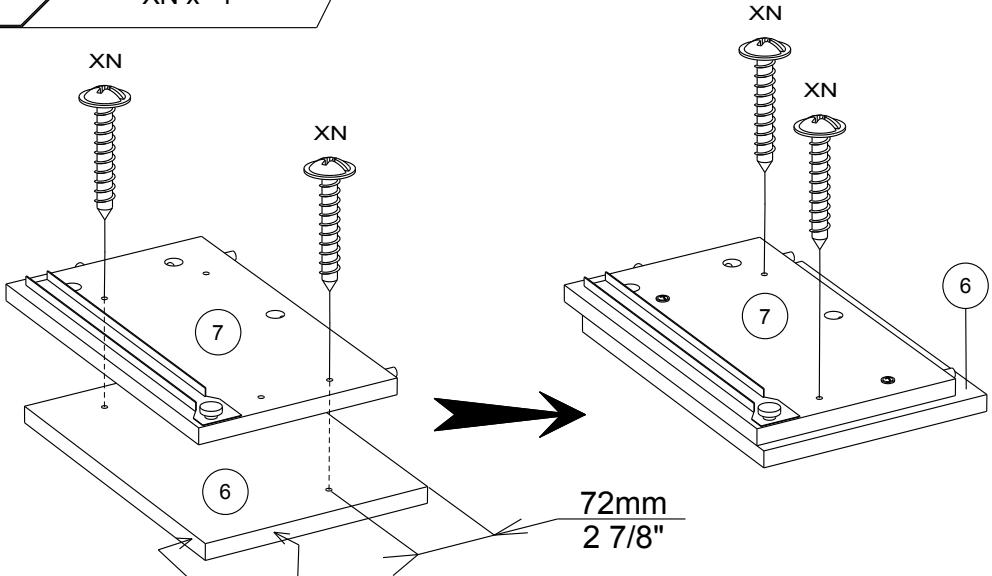
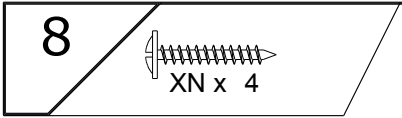
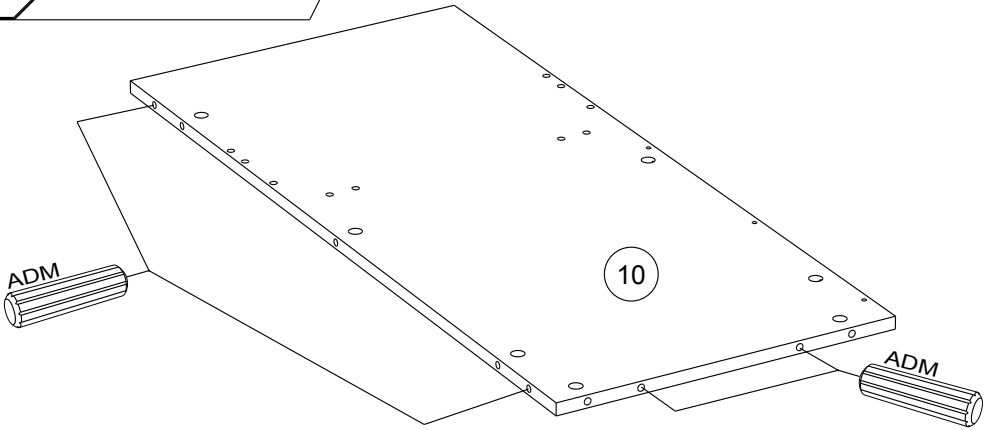

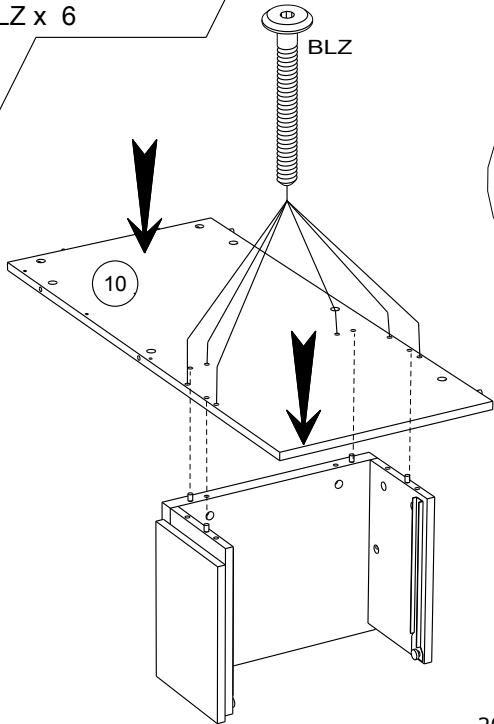
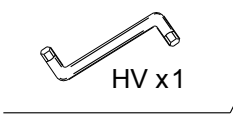
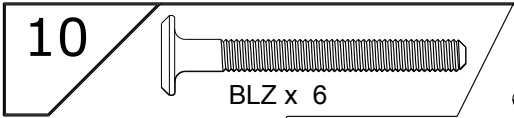
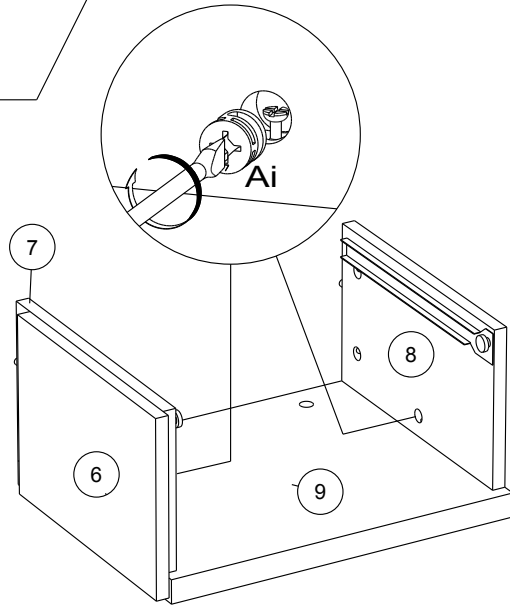
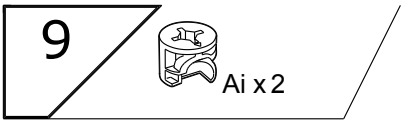

11



AQS x 1



BWF x 2



VG x 1



ADM x 3



AHX x 2

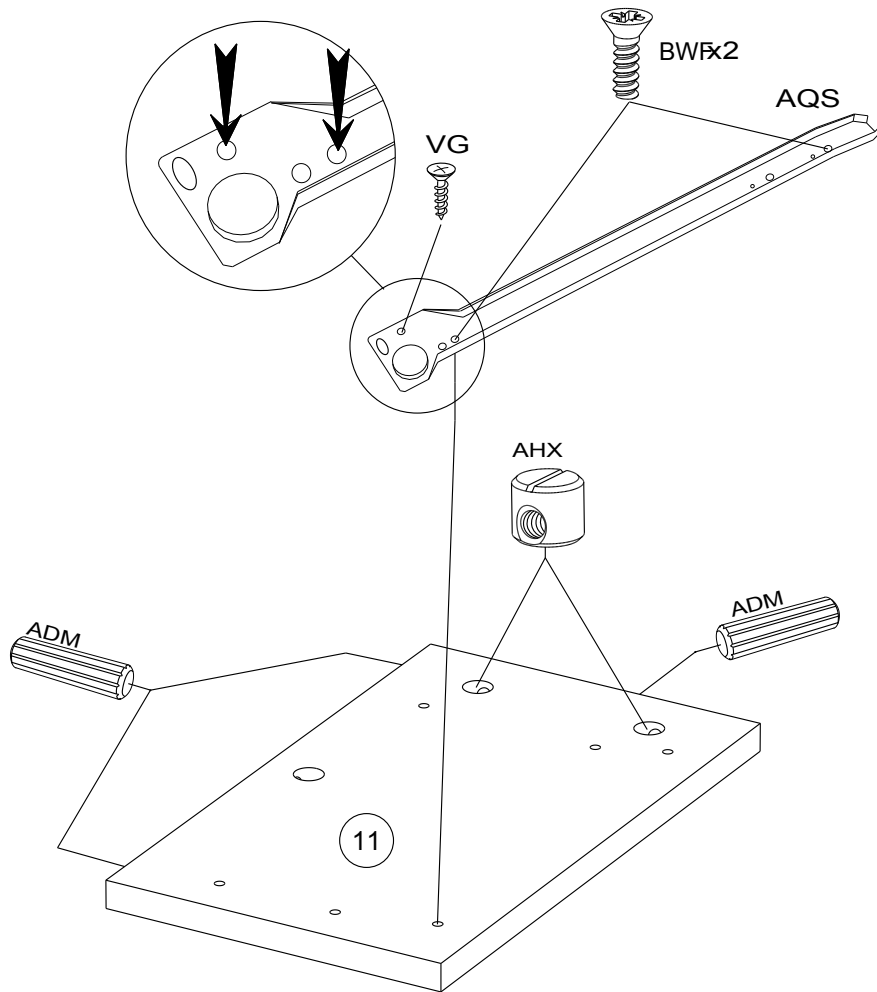

12

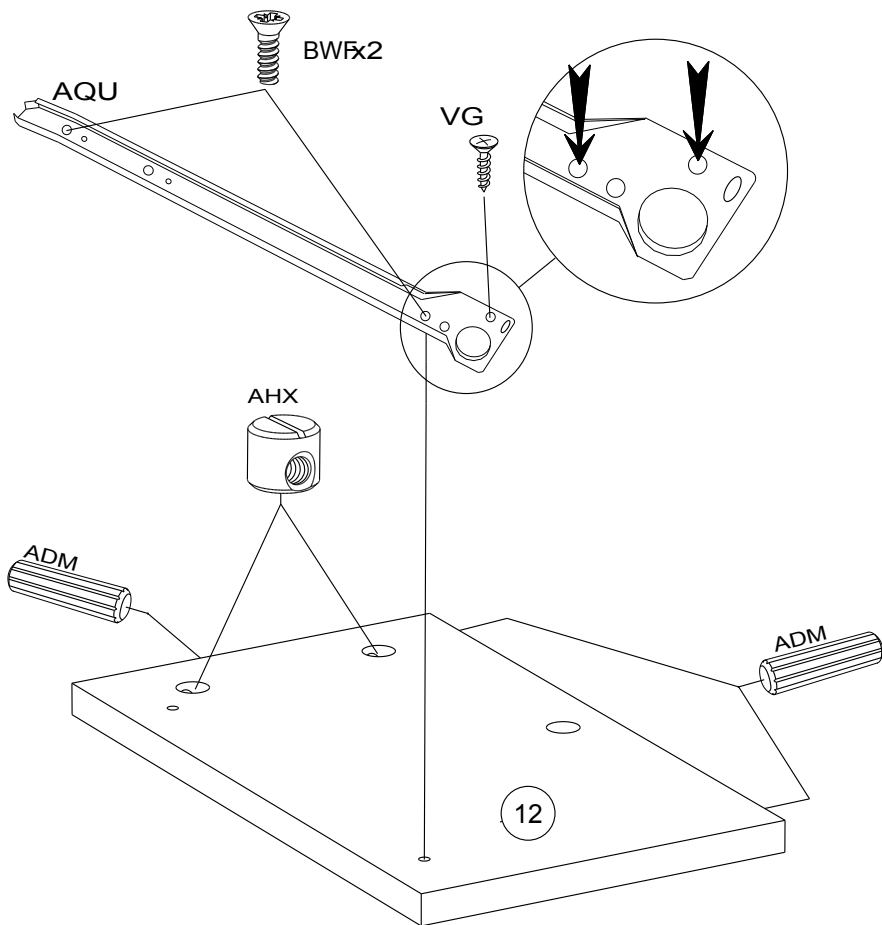
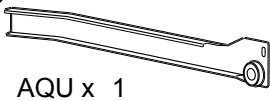

13



ADM x4

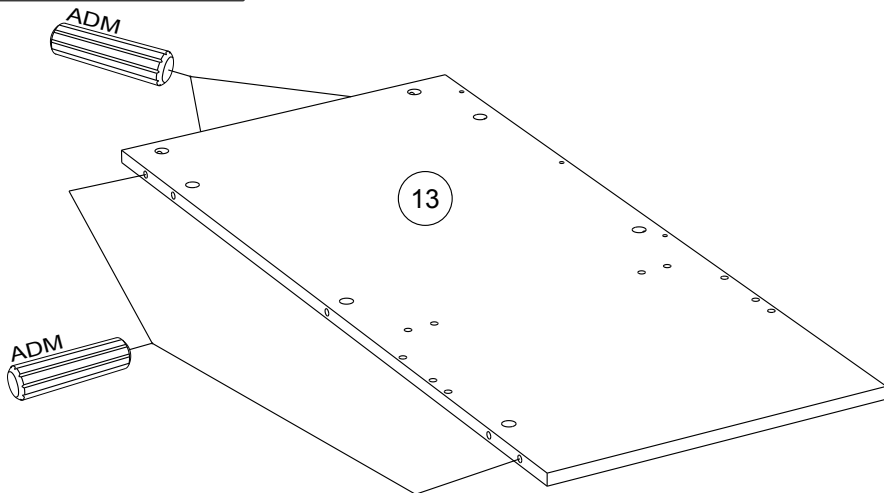

14



XN x 4

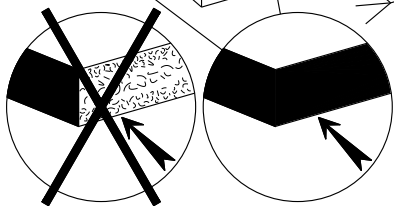
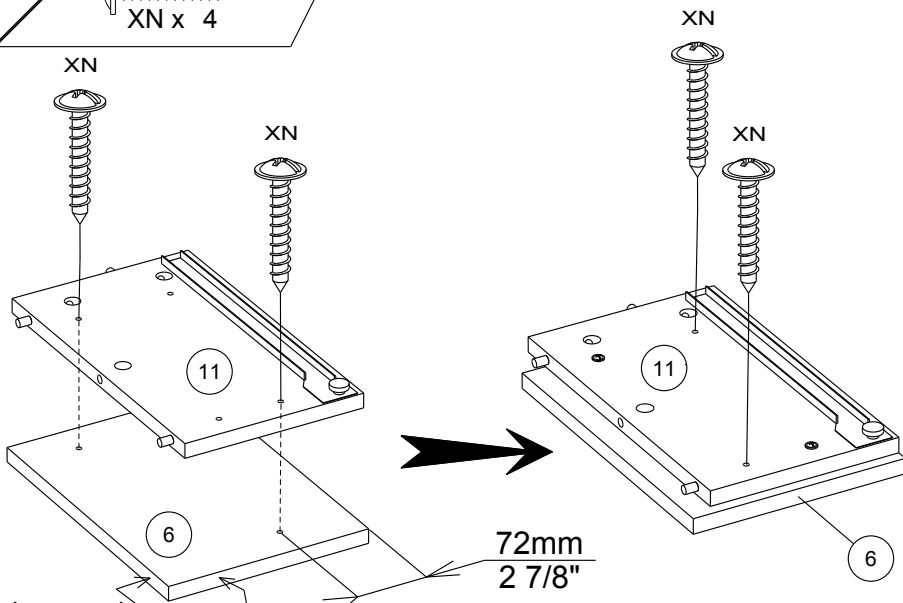

15



Ai x 2

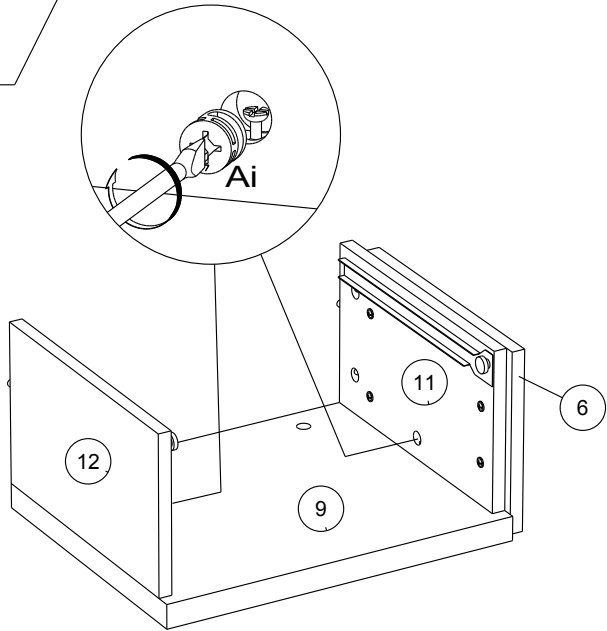

16

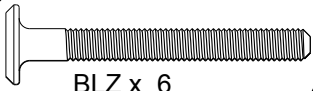

BLZ x 6



HV x 1

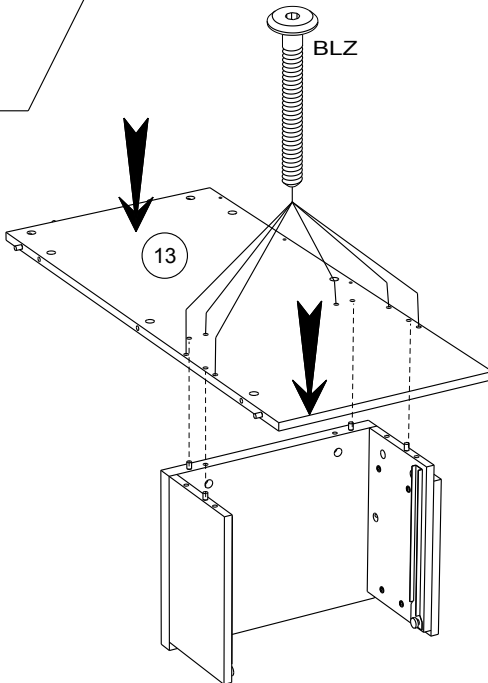

17

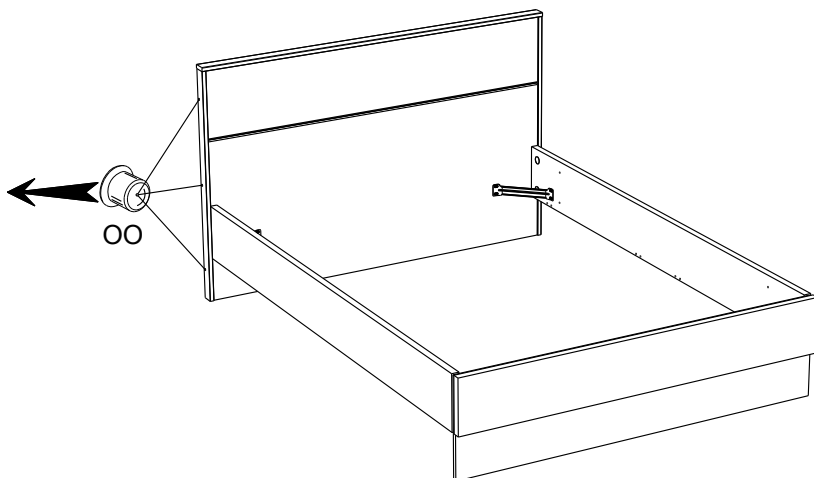

18

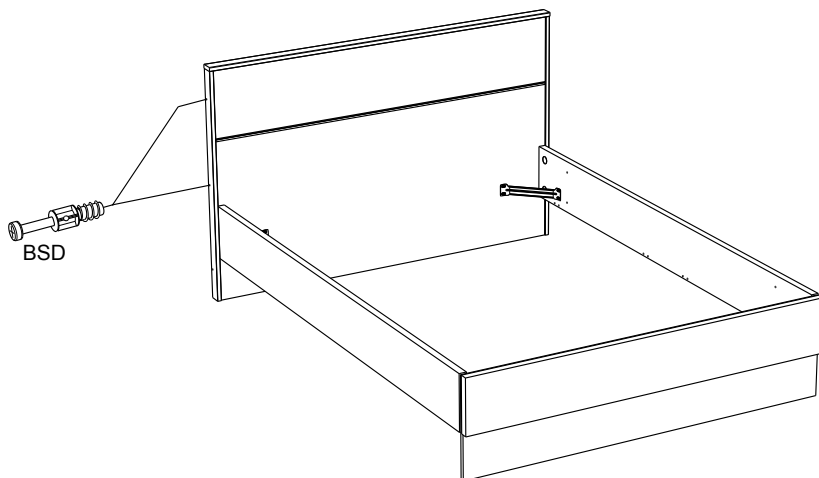
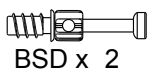

19

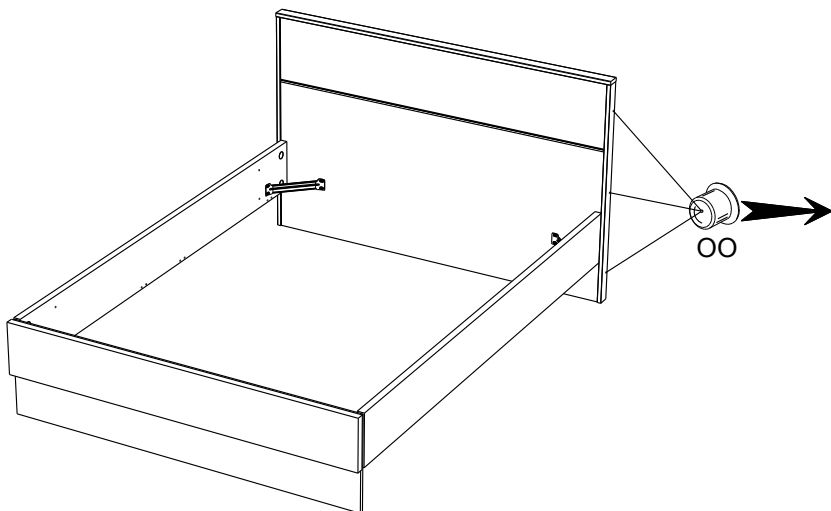

20

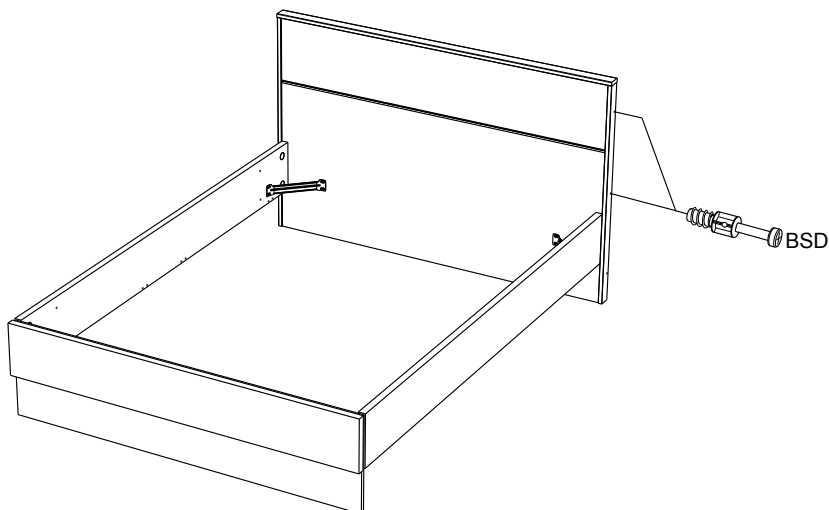
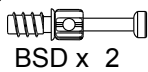

21



Ai x 2

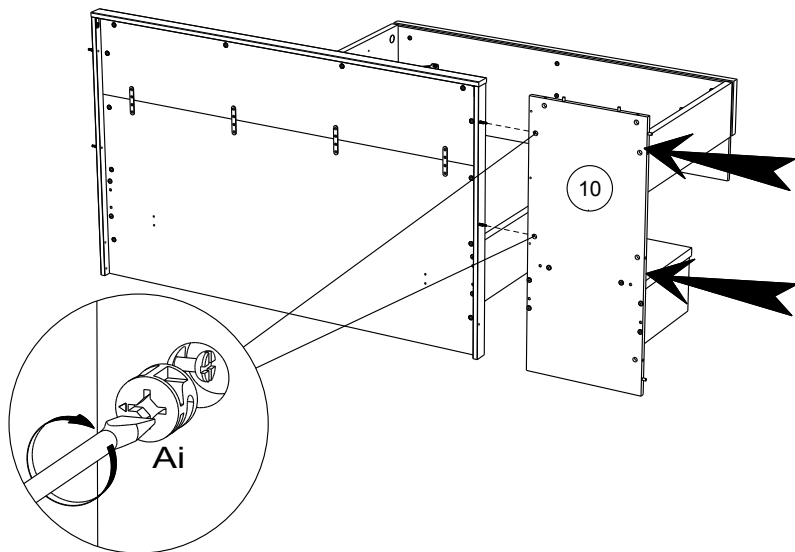

22



Ai x 2

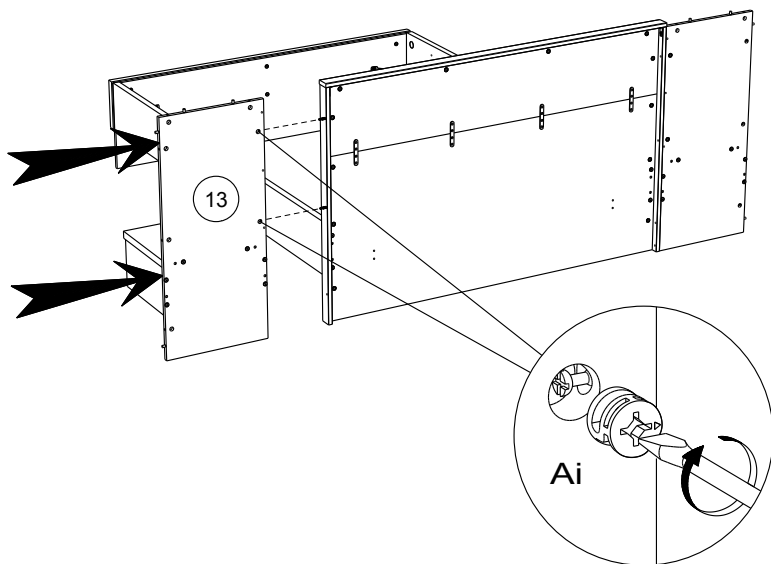

23

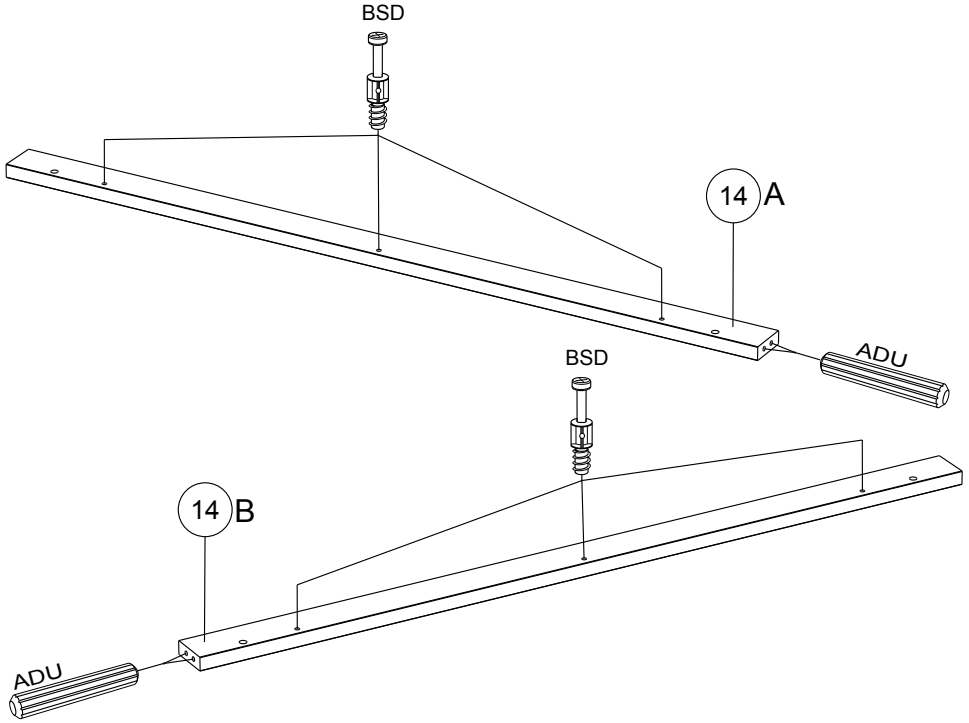
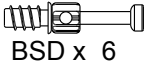

24

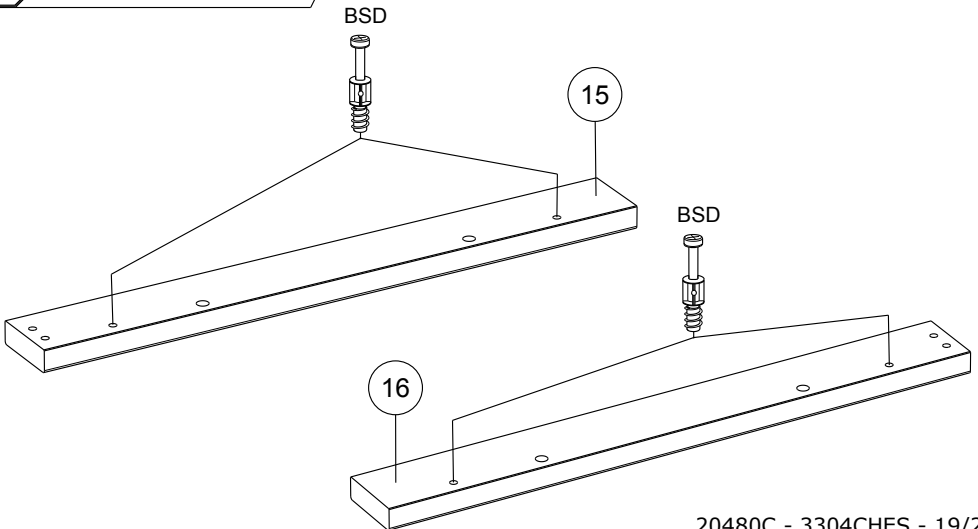
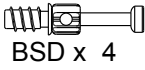

25



Ai x 3

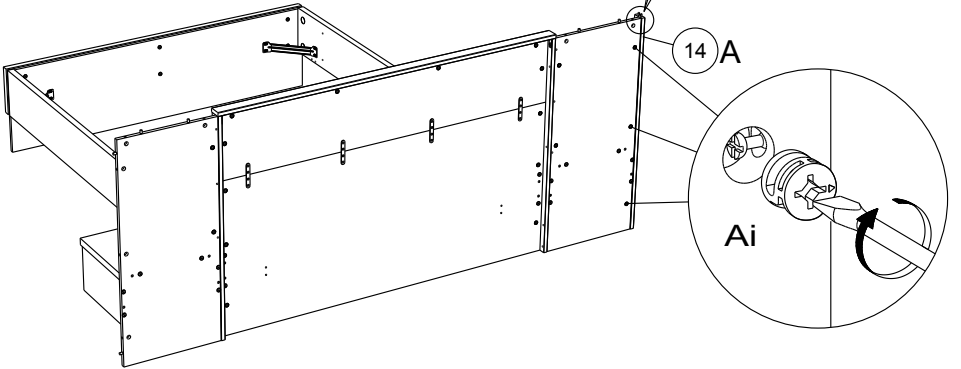

26



Ai x 3

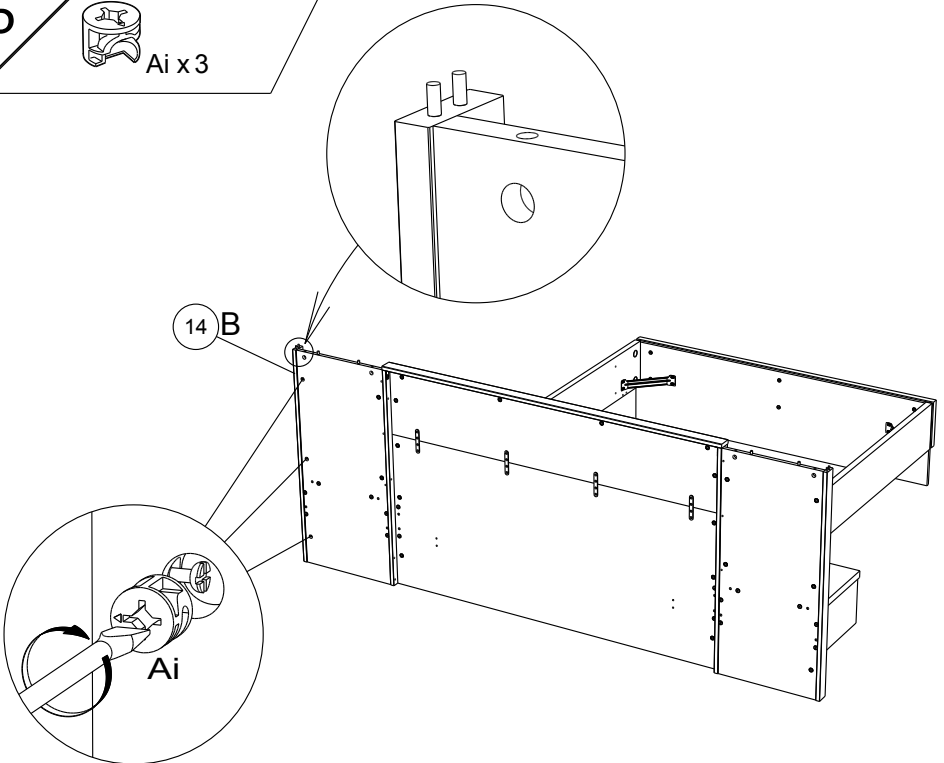

27



Ai x2

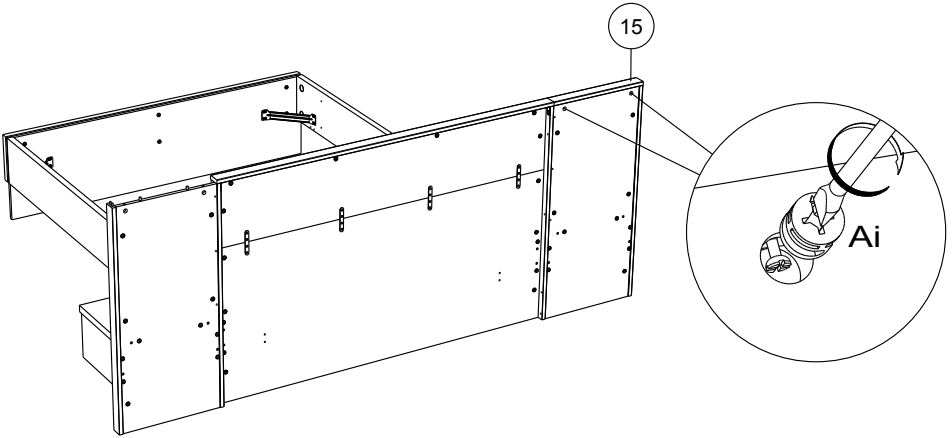

28



Ai x2

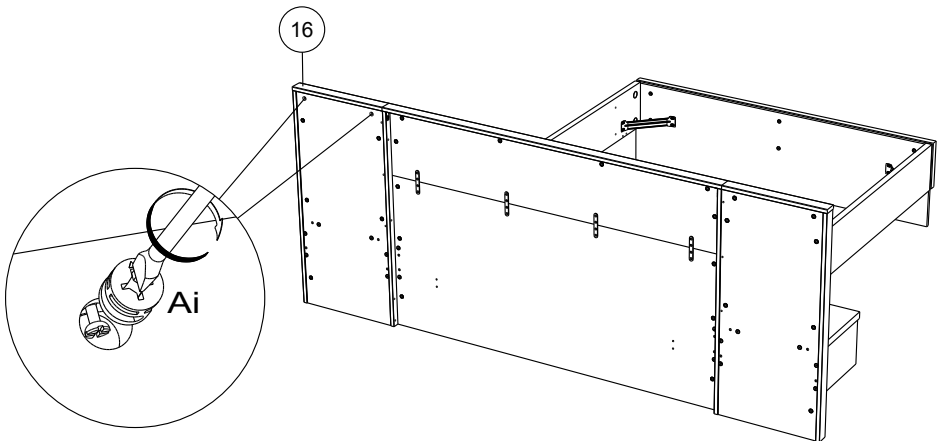

29

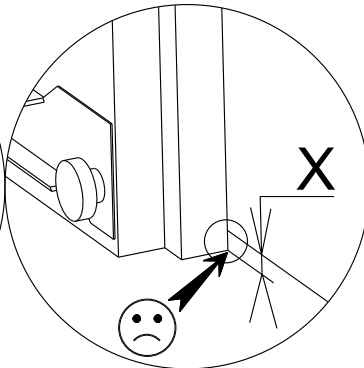
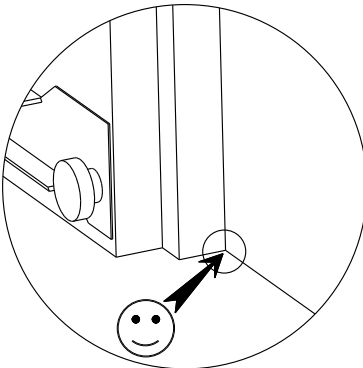
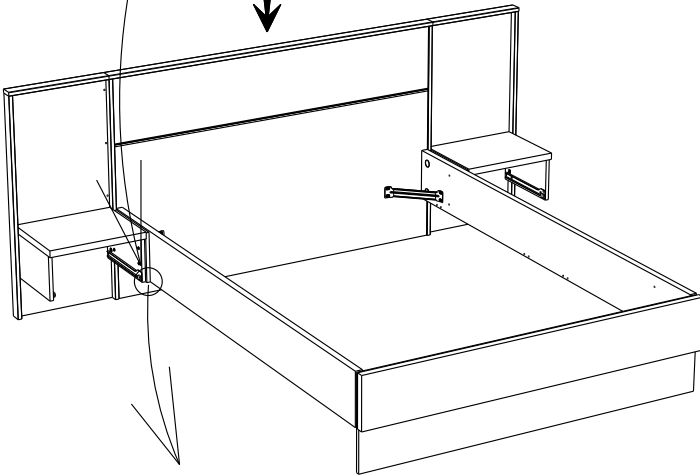
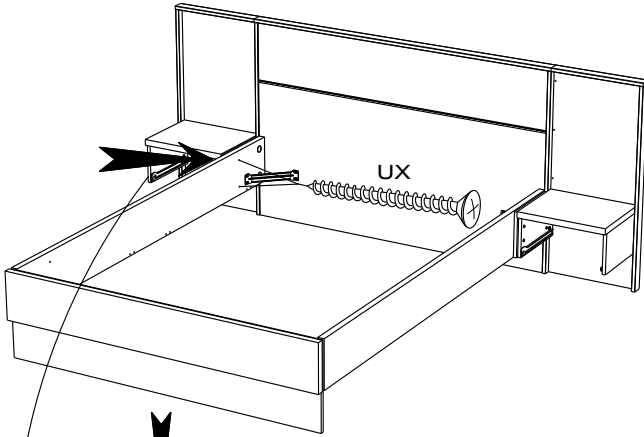
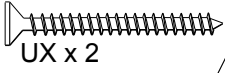

30

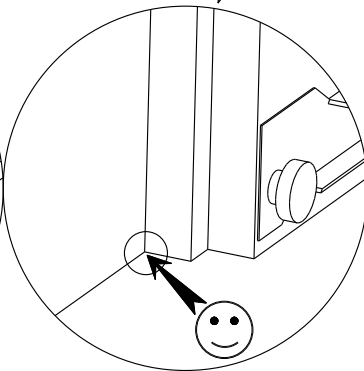
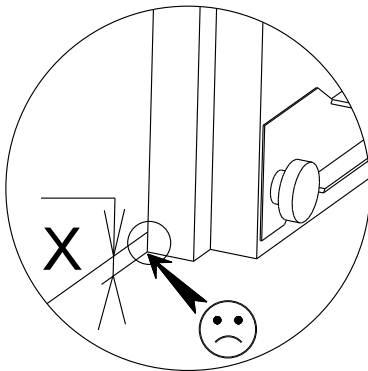
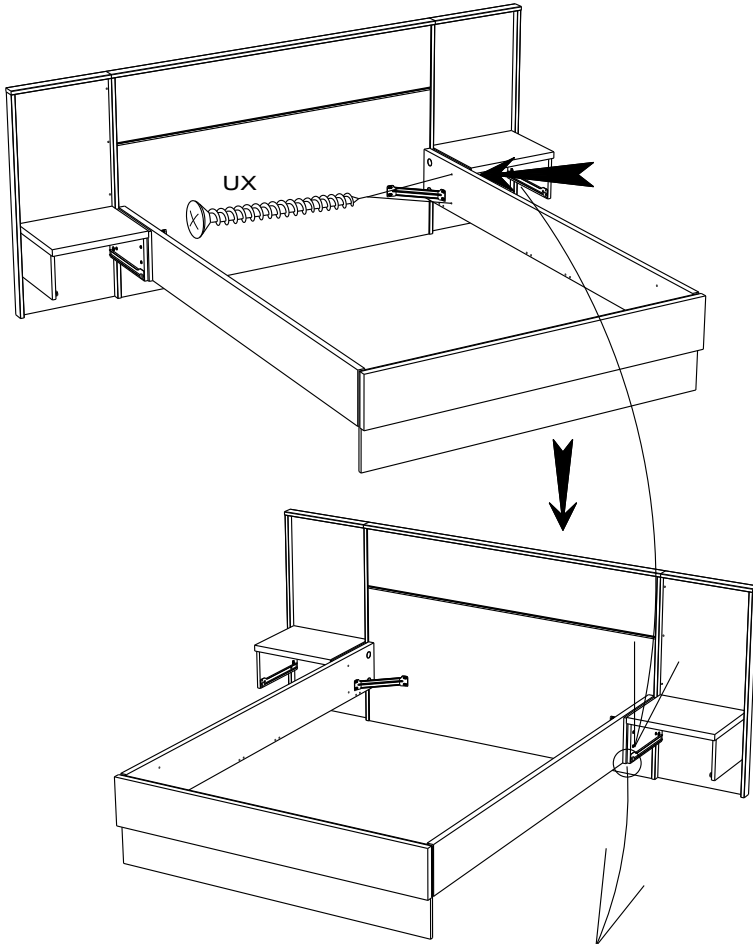

31

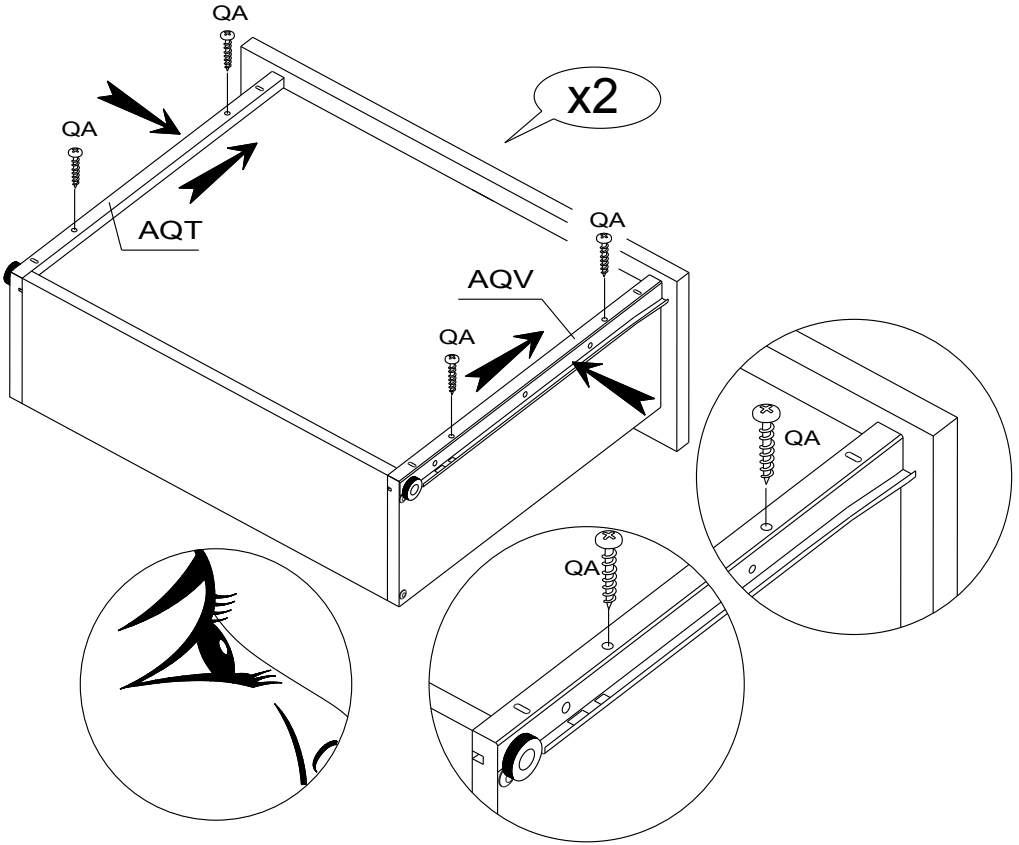
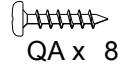
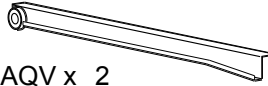

32

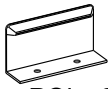

POi x 2



VG x 4

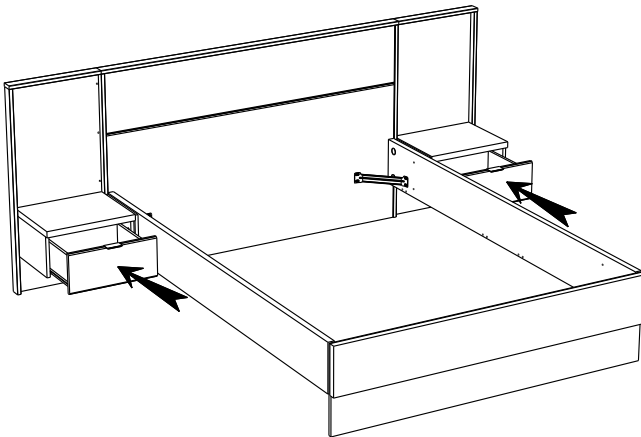
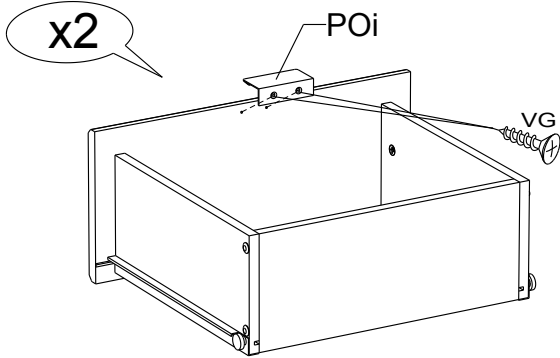

33

ANK x 4

XN x 6

