

- (FR)** NOTICE DE MONTAGE
- (EN)** ASSEMBLY INSTRUCTIONS
- (DE)** MONTAGEANLEITUNG
- (ES)** INSTRUCCIONES DE MONTAJE
- (NL)** MONTAGEVOORSCHRIFT
- (IT)** ISTRUZIONI DI MONTAGGIO
- (PT)** INSTRUÇÕES DE MONTAGEM
- (CR)** NAPUTCI ZA MONTAŽU
- (HU)** ÖSSZESZERELÉSI UTASÍTÁSOK

تعليمات التركيب (ع)

Max
22Kg / 48.5Lbs

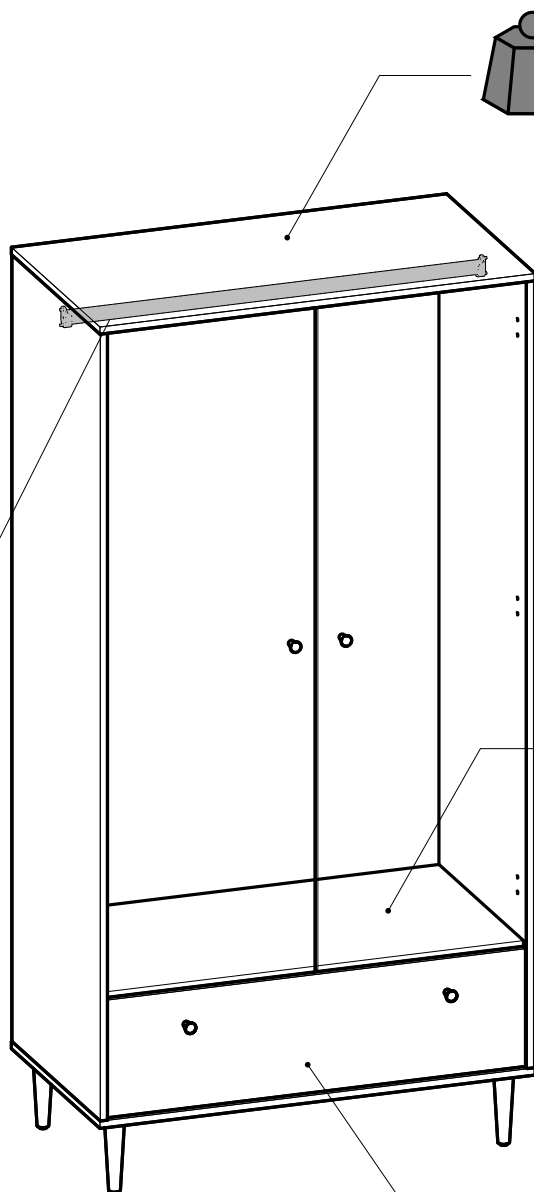

Max
19Kg / 41.9Lbs

Max
17Kg / 37.5Lbs

Max
9 Kg / 19.8Lbs

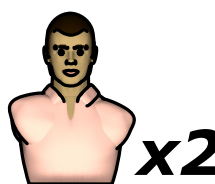
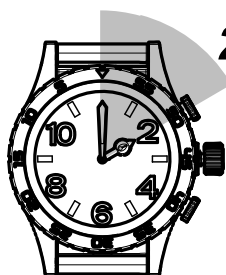

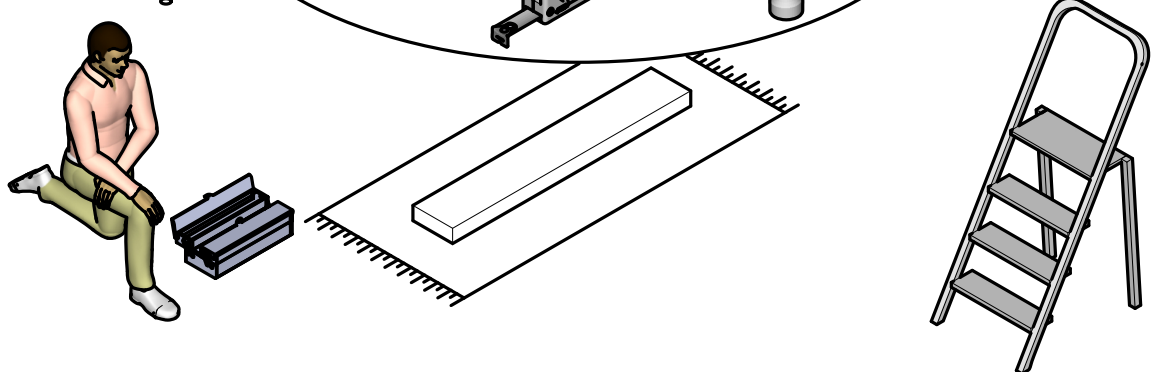
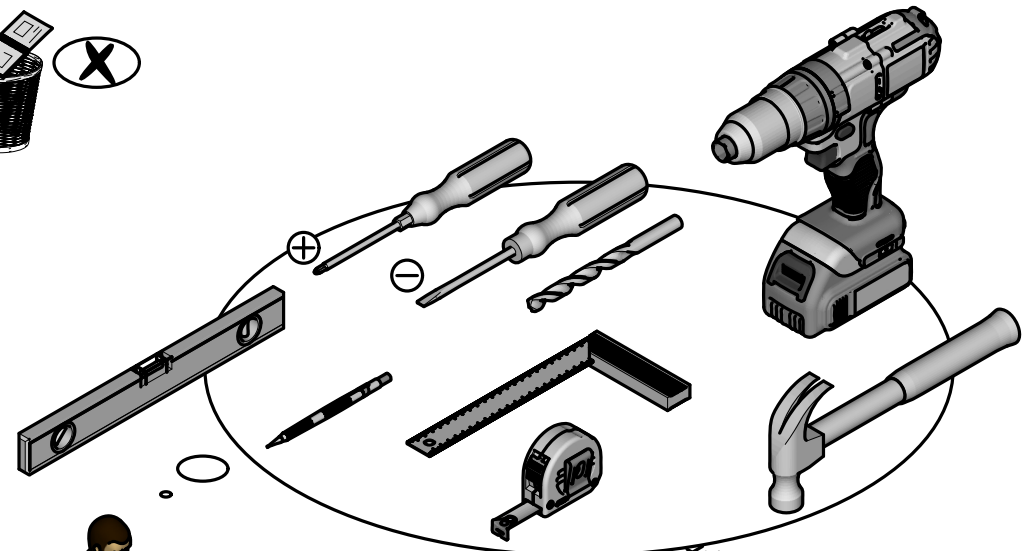
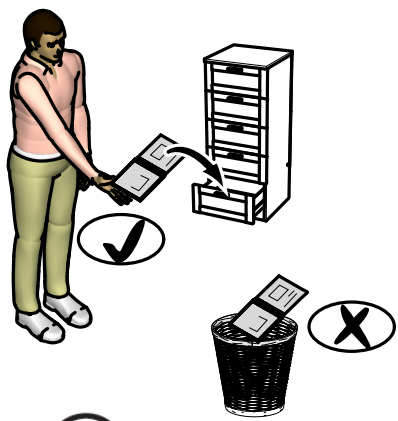
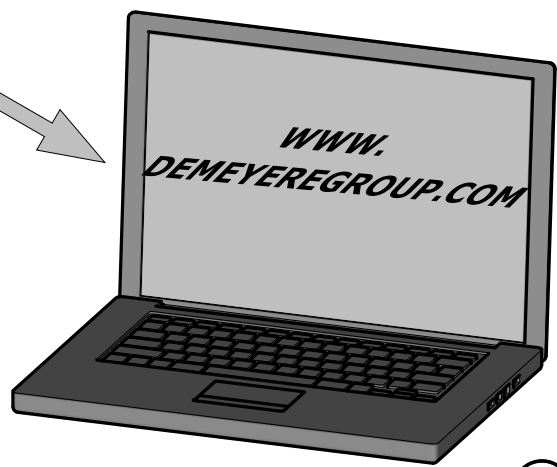
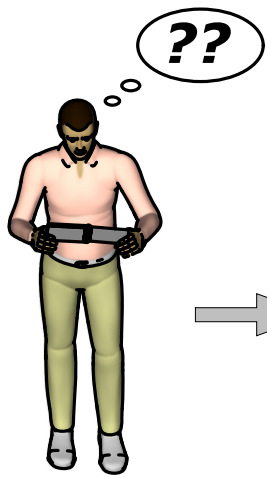

<https://www.demeyseregroup.com>

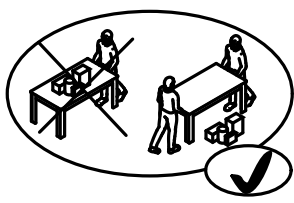
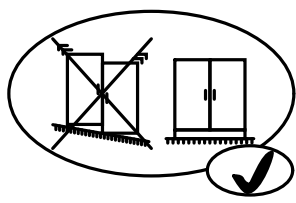
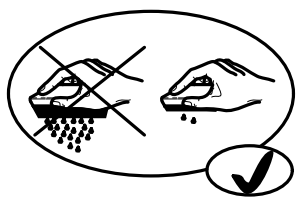
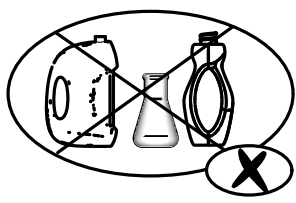



A x1

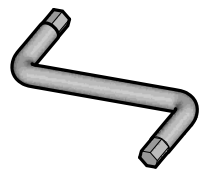

B x1

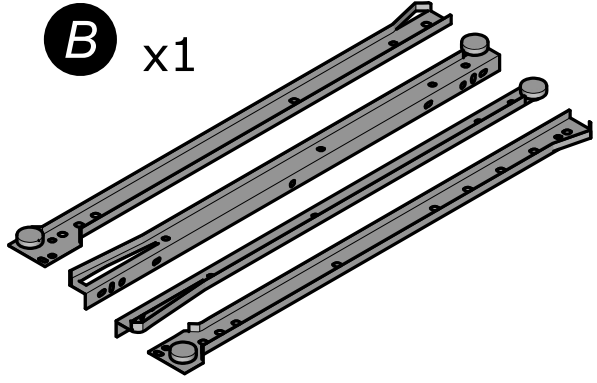

C x12

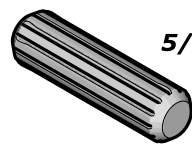

8x30mm
5/16" x 1 3/16"

D x2



3x12mm
1/8" x 15/32"

E x4



3x16mm
1/8" x 5/8"

F x4

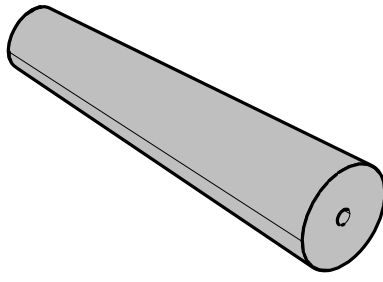

G x4

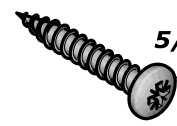

4x25mm
5/32" x 1"

H x6



6,3x9mm
1/4" x 11/32"

I x8



3x12mm
1/8" x 15/32"

J x12

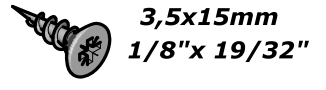

3,5x15mm
1/8" x 19/32"

K x2

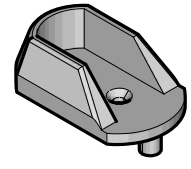

L x14



M x12

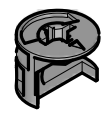

Ø15mm
Ø19/32"

N x1

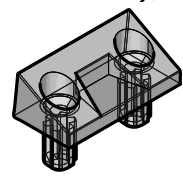

O x1

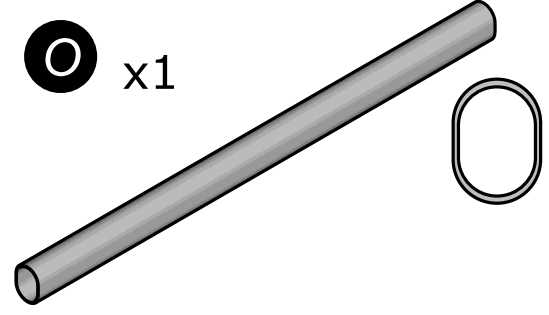

P x1

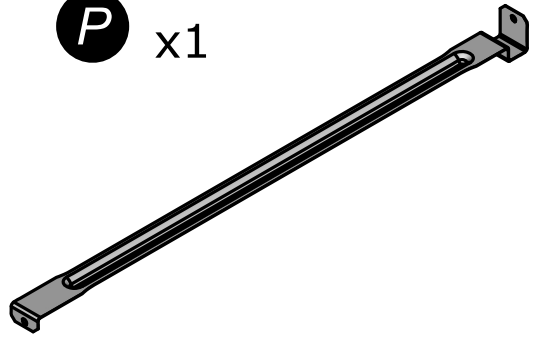

Q x1

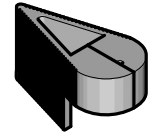

R x2

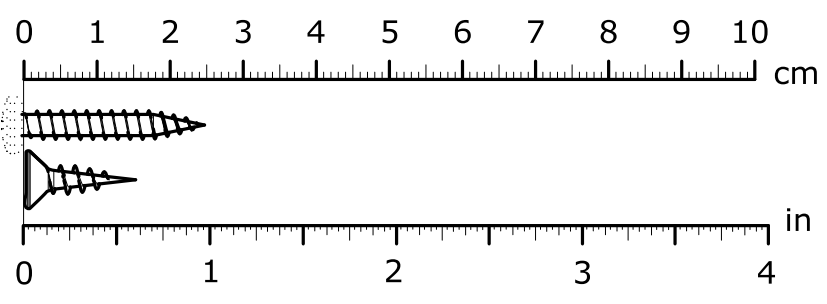
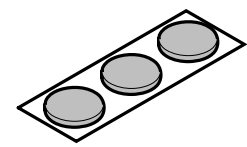

S x6

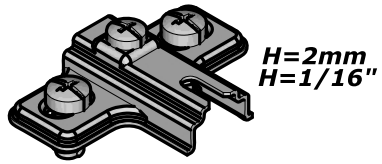

T x6

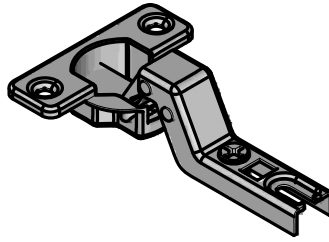

U x1

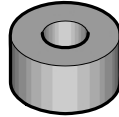

V x4

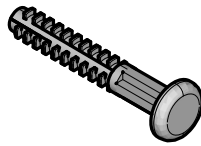

W x4

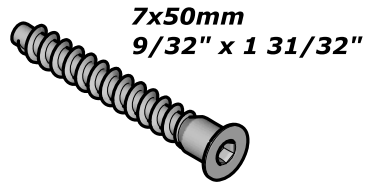

X x1

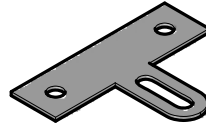

Y x2

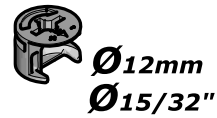

Z x2

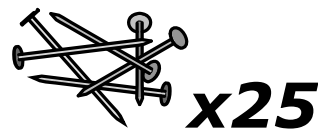

AA x4

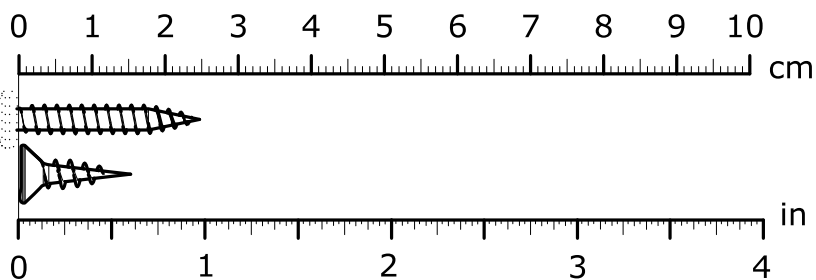
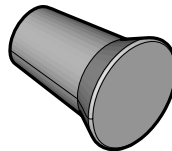

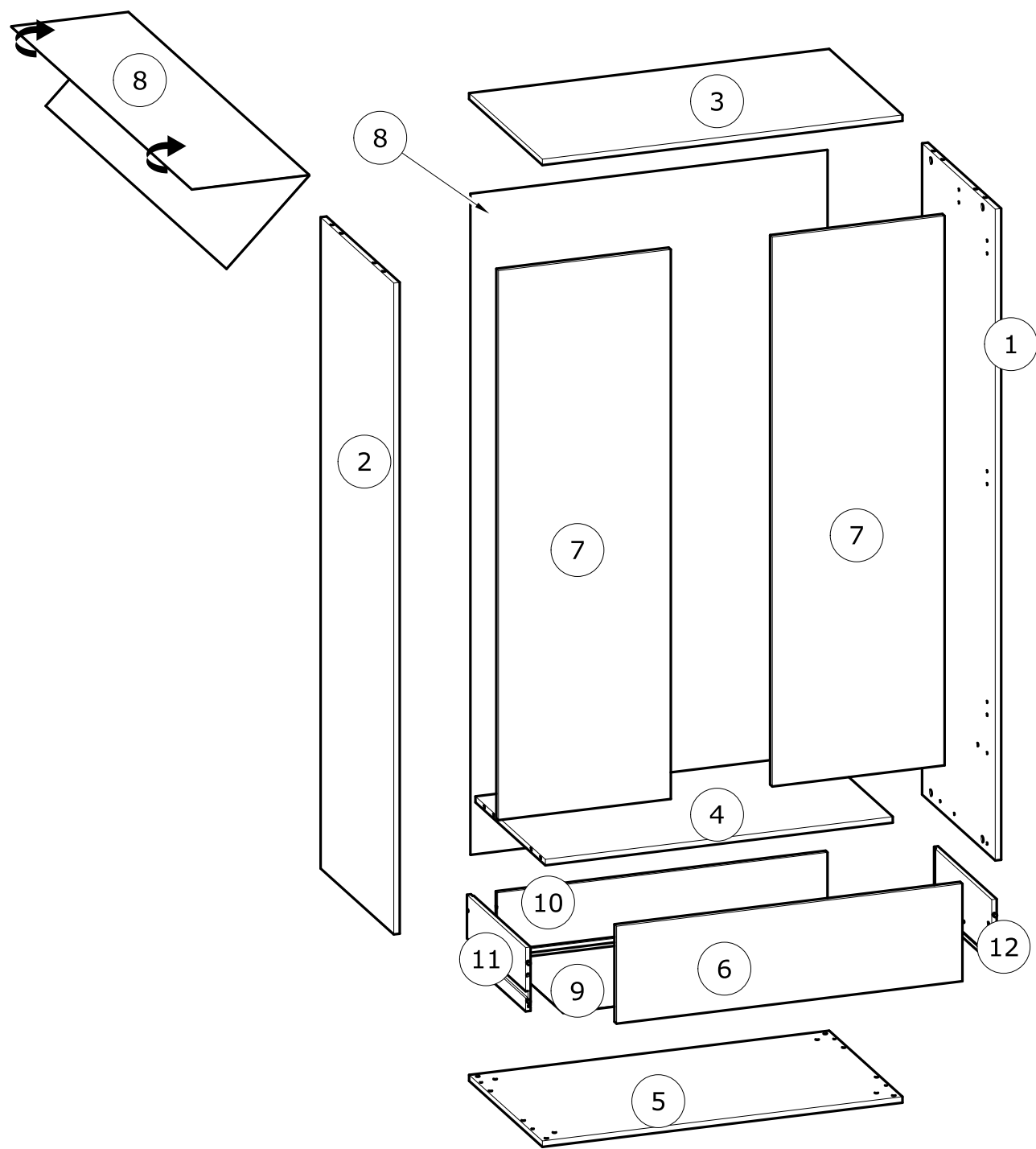

N°	MM		INCH		QTY
1	1 631	x 499	64 3/16	x 19 10/16	1
2	1 631	x 499	64 3/16	x 19 10/16	1
3	907	x 500	35 11/16	x 19 11/16	1
4	875	x 477	34 7/16	x 18 12/16	1
5	907	x 500	35 11/16	x 19 11/16	1
6	871	x 244	34 5/16	x 9 10/16	1

N°	MM		INCH		QTY
7	1 376	x 434	54 3/16	x 17 1/16	2
8	1 655	x 899	65 3/16	x 35 6/16	1
9	837	x 398	32 15/16	x 15 11/16	1
10	831	x 160	32 11/16	x 6 5/16	1
11	400	x 160	15 12/16	x 6 5/16	1
12	400	x 160	15 12/16	x 6 5/16	1

FR

AVERTISSEMENT : MEUBLE A FIXER IMPERATIVEMENT AU MUR AFIN D'EVITER SON BASCULEMENT

- Pour installer correctement ce produit et éliminer les risques pour votre sécurité, merci de suivre exactement ce manuel d'instruction.
- Fixer le meuble au mur avec les attaches prévues à cet effet
- Les vis et les chevilles ne sont pas fournies. Utiliser des vis et des chevilles adaptées au support.

EN

WARNING: FURNITURE TO BE ATTACHED TO THE WALL TO PREVENT OVERTURNING

- Installation shall be carried out exactly according to those instructions-otherwise a safety risk can occur if incorrectly installed;
- Attach the furniture to the wall with the fastening provided for this purpose
- Screw and Pegs are not supplied. Use Screws and pegs adapted to the support.

DE

WARNUNG: DAS MÖBEL MUSS AN DER WAND BEFESTIGT WERDEN, UM ZU VERHINDEN DASS ES KIPPT

- Um das Produkt korrekt zu installieren und um Risiken für Ihre Sicherheit zu verhindern, die Gebrauchsanleitung genauestens befolgen.
- Das Möbel mit den vorgesehenen Befestigungen an einer Wand befestigen.
- Schrauben und Dübel sind nicht im Lieferumfang enthalten. Passende Schrauben und Dübel verwenden.

ES

ADVERTENCIA: ESTE MUEBLE DEBE ESTAR SIEMPRE FIJO EN LA PARED PARA EVITAR QUE VUELQUE

- Para instalar correctamente este producto y eliminar los riesgos para la seguridad, seguir exactamente las instrucciones del manual.
- Fijar el mueble a la pared con las sujeciones previstas a este efecto.
- Los tornillos y los tacos no están incluidos. Utilizar tornillos y tacos adaptados al soporte.

NL

WAARSCHUWING: MEUBEL MOET VERPLICHT AAN DE MUUR BEVESTIGD WORDEN ZODAT HET NIET KAN OMVALLEN

- Om dit product correct te installeren en alle risico's voor uw veiligheid te elimineren, gelieve de instructies in deze handleiding nauwgezet op te volgen.
- Zet het meubel vast aan de muur met de hiertoe voorziene bevestigingen.
- De schroeven en pluggen zijn niet meegeleverd. Gebruik schroeven en pluggen die geschikt zijn voor het materiaal van de muur.

IT

AVVERTENZA: MOBILE DA FISSARE IMPERATIVAMENTE AL MURO PER EVITARE CHE SI RIBALTI

- Per installare correttamente questo prodotto ed eliminare i rischi per la vostra sicurezza, si prega di seguire esattamente il manuale d'istruzioni.
- Fissare il mobile al muro con gli appositi ganci.
- Le viti e i tasselli non sono forniti. Utilizzare viti e tasselli adatti al supporto.

PT

ADVERTÊNCIA: MÓVEL A FIXAR OBRIGATORIAMENTE À PAREDE PARA EVITAR A SUA QUEDA

- Para instalar corretamente este produto e eliminar os riscos para a sua segurança, é favor seguir exatamente este manual de instruções.
- Fixe o móvel à parede com as fixações previstas para o efeito
- Os parafusos e as cavilhas não são fornecidos. Utilize parafusos e cavilhas adaptados ao suporte.

CR

UPOZORENJE : UČVRSTITE ORMARIĆ NA ZID KAKO BISTE SPRIJEČILI NJEGOVO LJULJANJE

- Kako biste pravilno postavili ovaj proizvod i uklonili sigurnosne rizike kojima se izlažete, pridržavajte se strogo ovog priručnika s uputama.
- Postavite ormarić na zid pripadajućim sponama.Vijci i svornjci ne isporučuju se. Upotrijebite nosne vijke i svornjke.

Hu

FIGYELEM: A BÚTORT FELTÉTENÜL RÖGZÍTENI KELL A FALHOZ, HOGY ELKERÜLJE A FELBILLENÉSÉT

- A termék megfelelő elhelyezéséhez és a biztonságot érintő kockázatok kiküszöböléséhez pontosan kövesse ezt a használati útmutatót.
- Rögzítse a bútort a falhoz az erre a célra szolgáló rögzítőelemekkel.
- A csavarok és a tiplik nincsenek mellékelve. Használjon a tartóhoz illő csavarokat és tipliket.

العربية:

تحذير: قطعة أثاث يلزم تثبيتها على الحائط لتجنب تآرجحها

- لتركيب هذا المنتج بشكل صحيح وتجنب المخاطر من أجل سلامتك، يرجى اتباع كتيب التعليمات هذا بالضبط.
- تثبت قطعة الأثاث على الحائط بواسطة العلاقات المخصصة لهذا الغرض
- إن البراغي والخوابير غير متوفرة مع المنتج. تستخدم براغي وخوابير ملائمة للحائط الذي يتم التثبيت عليه.

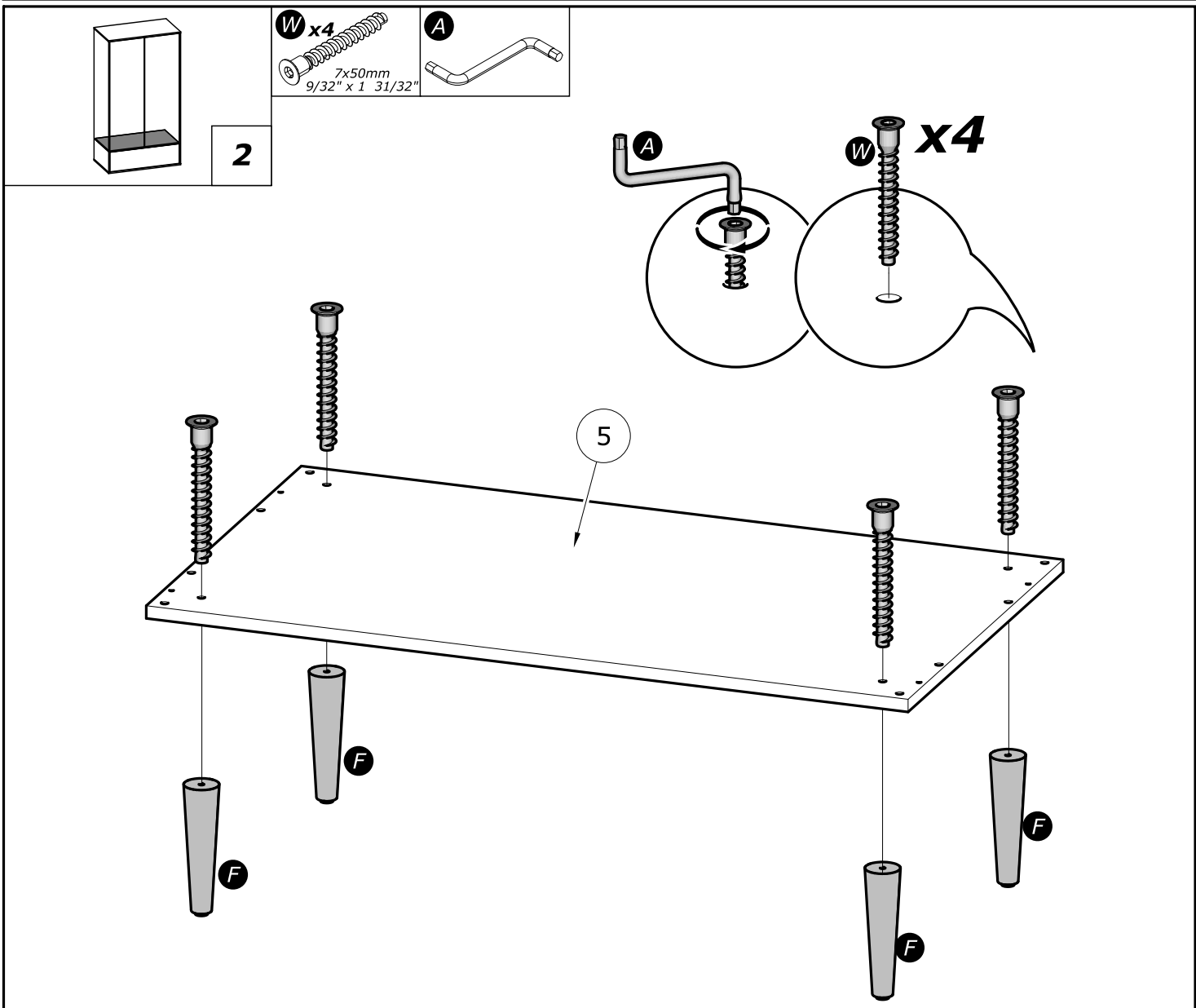
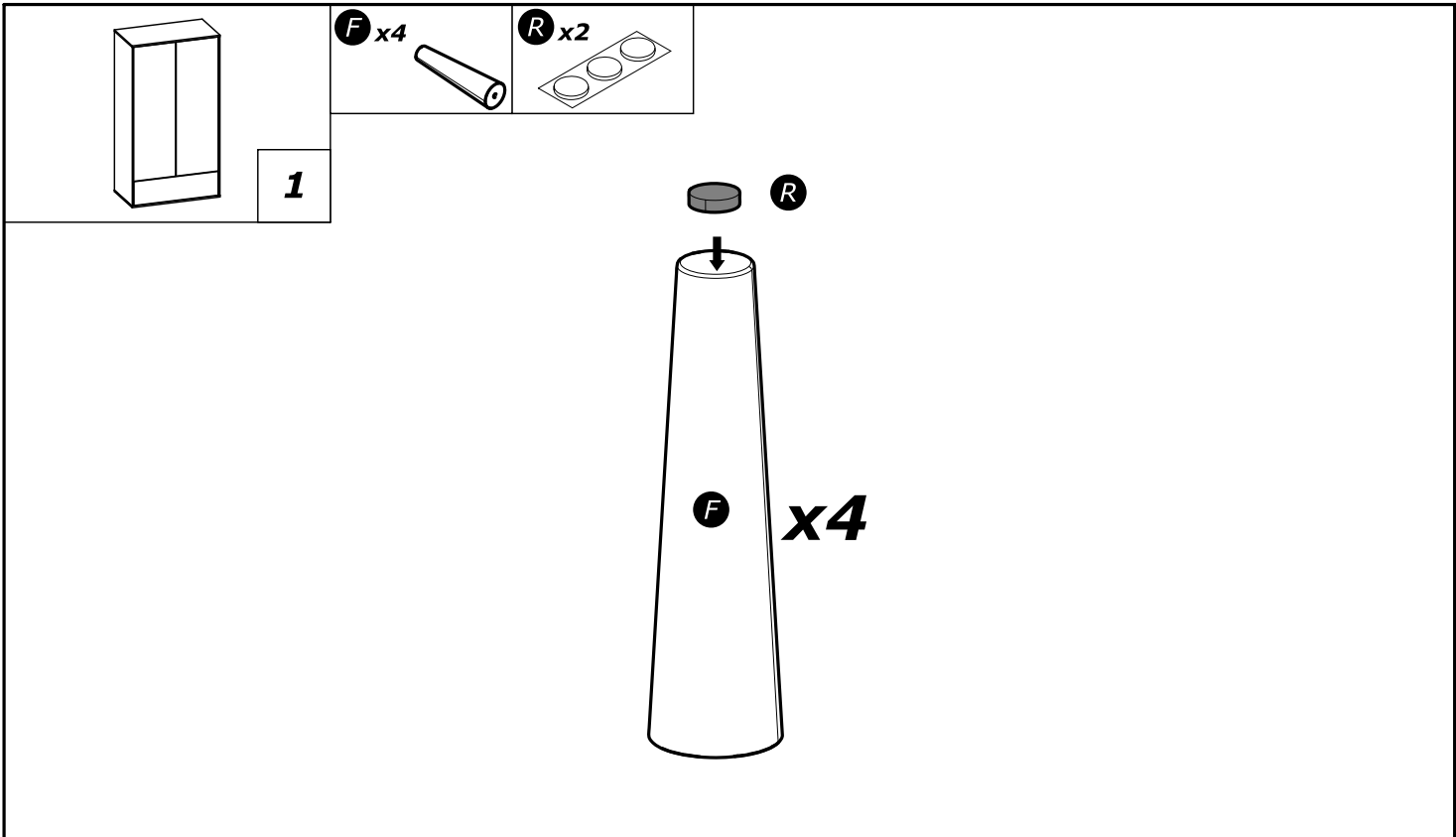

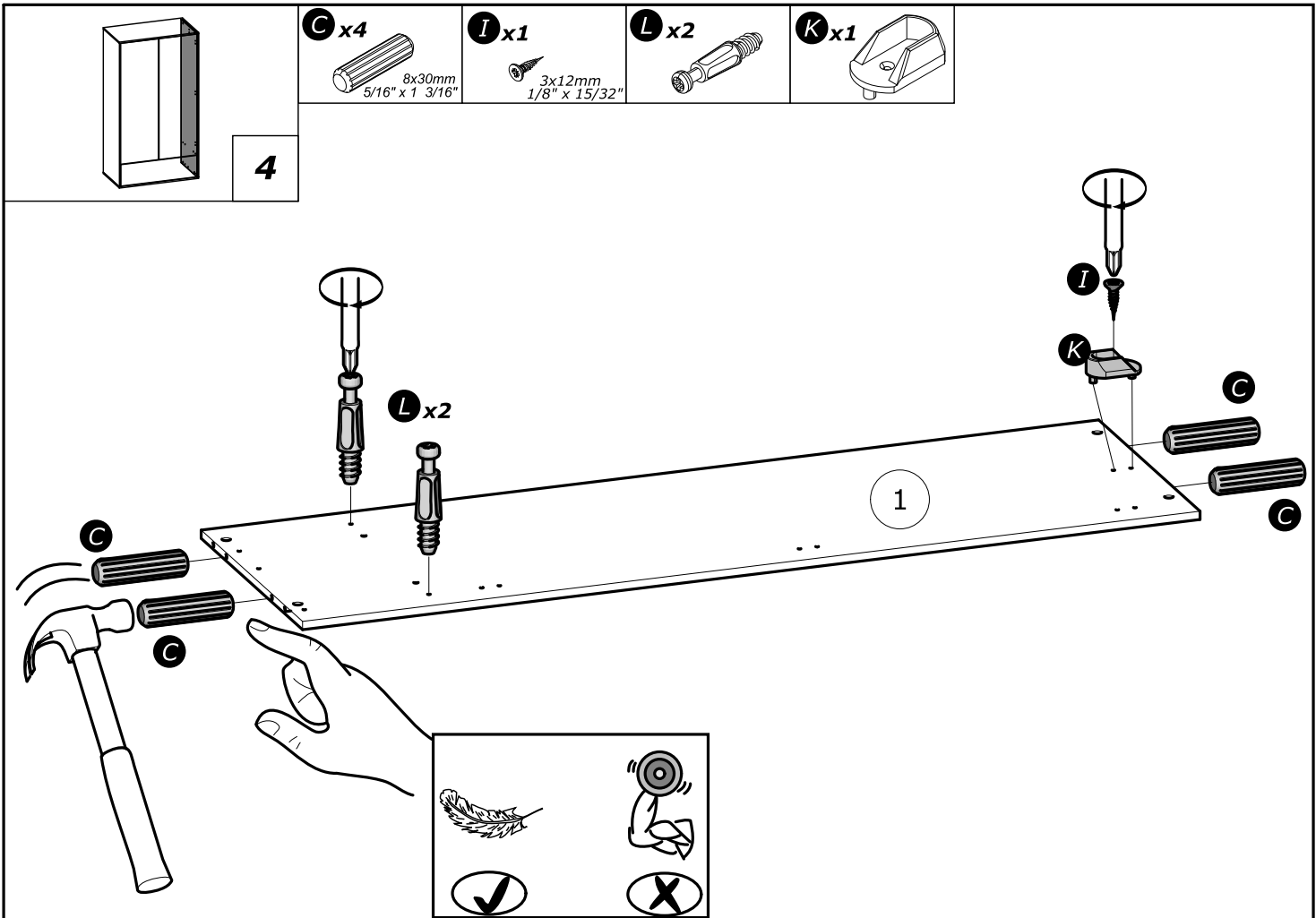
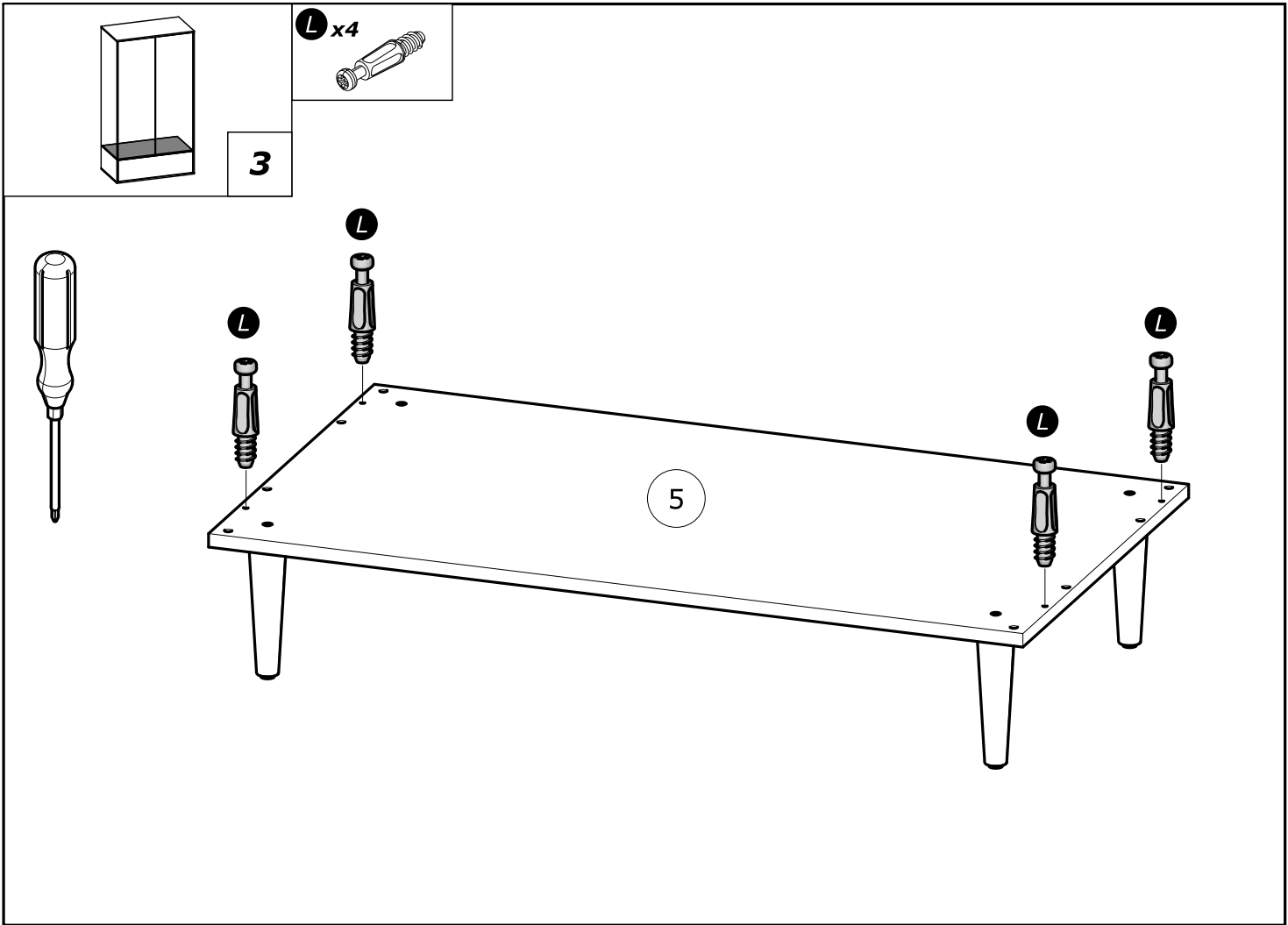

C x4
8x30mm
5/16" x 1 3/16"

I x1
3x12mm
1/8" x 15/32"

L x2

K x1

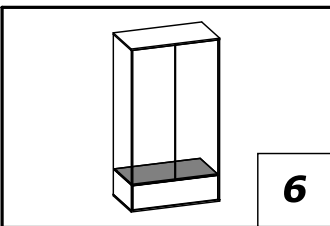
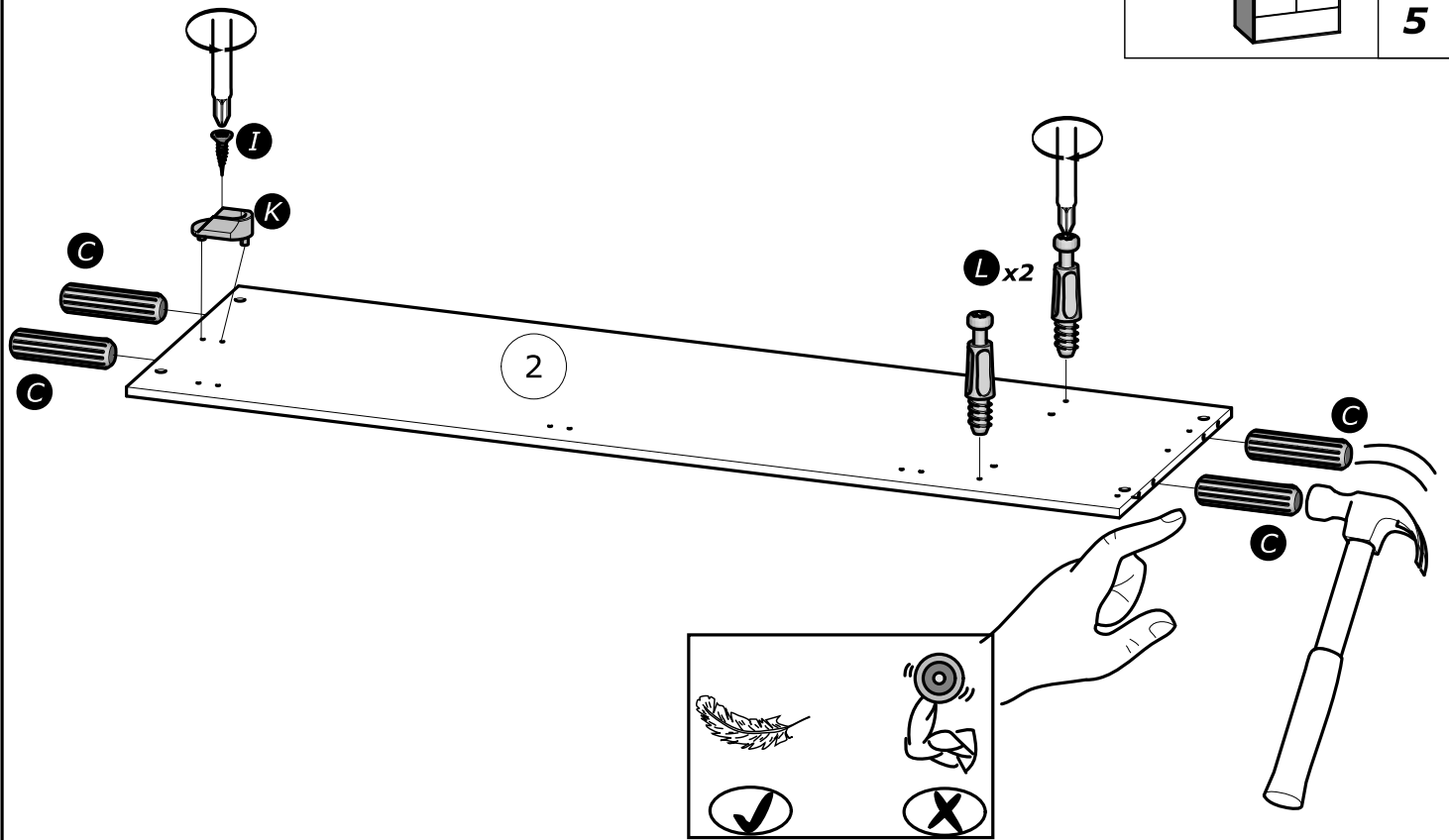
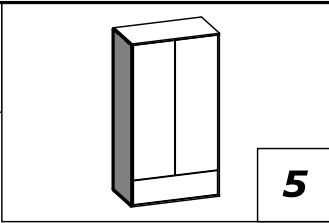

C x4
8x30mm
5/16" x 1 3/16"

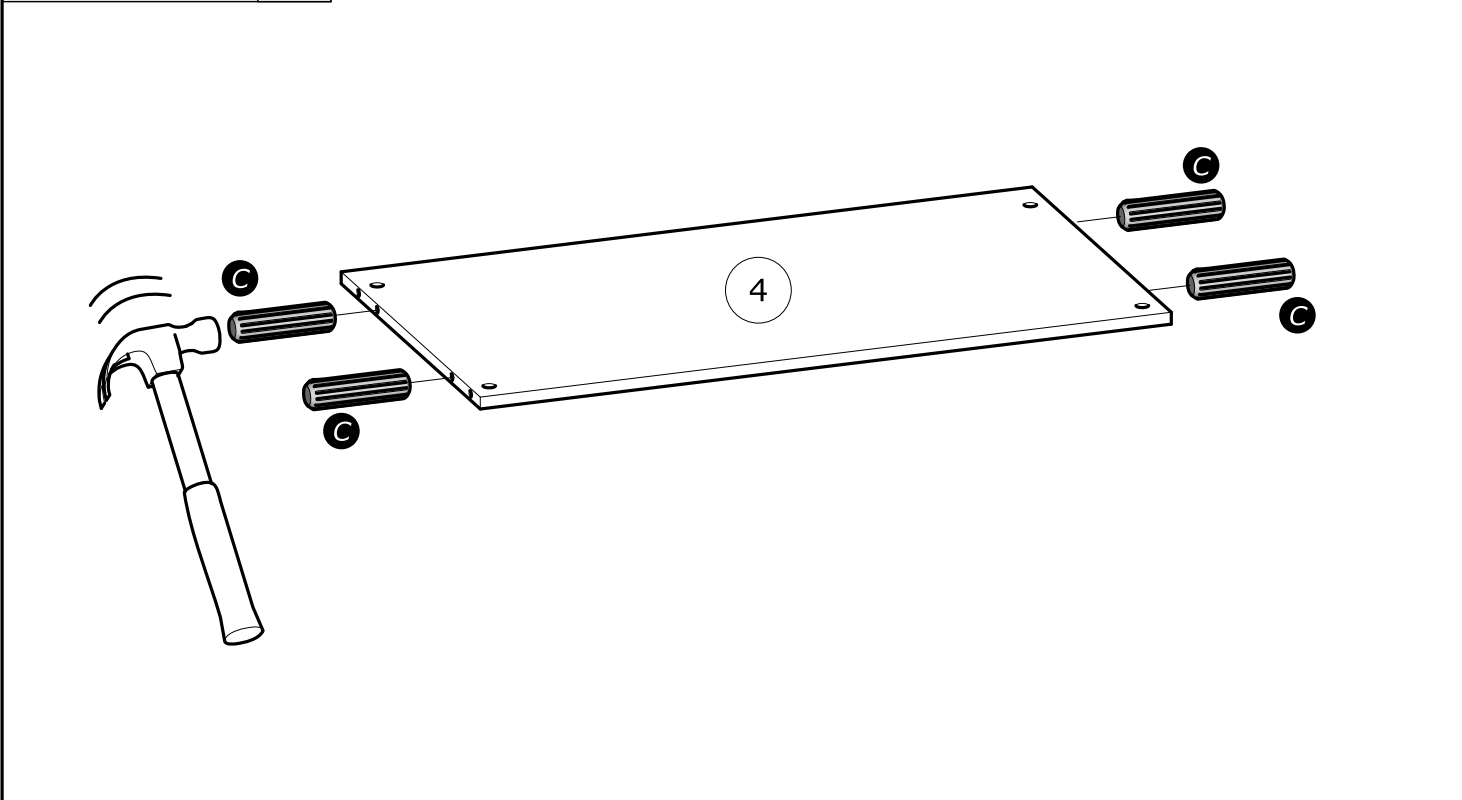

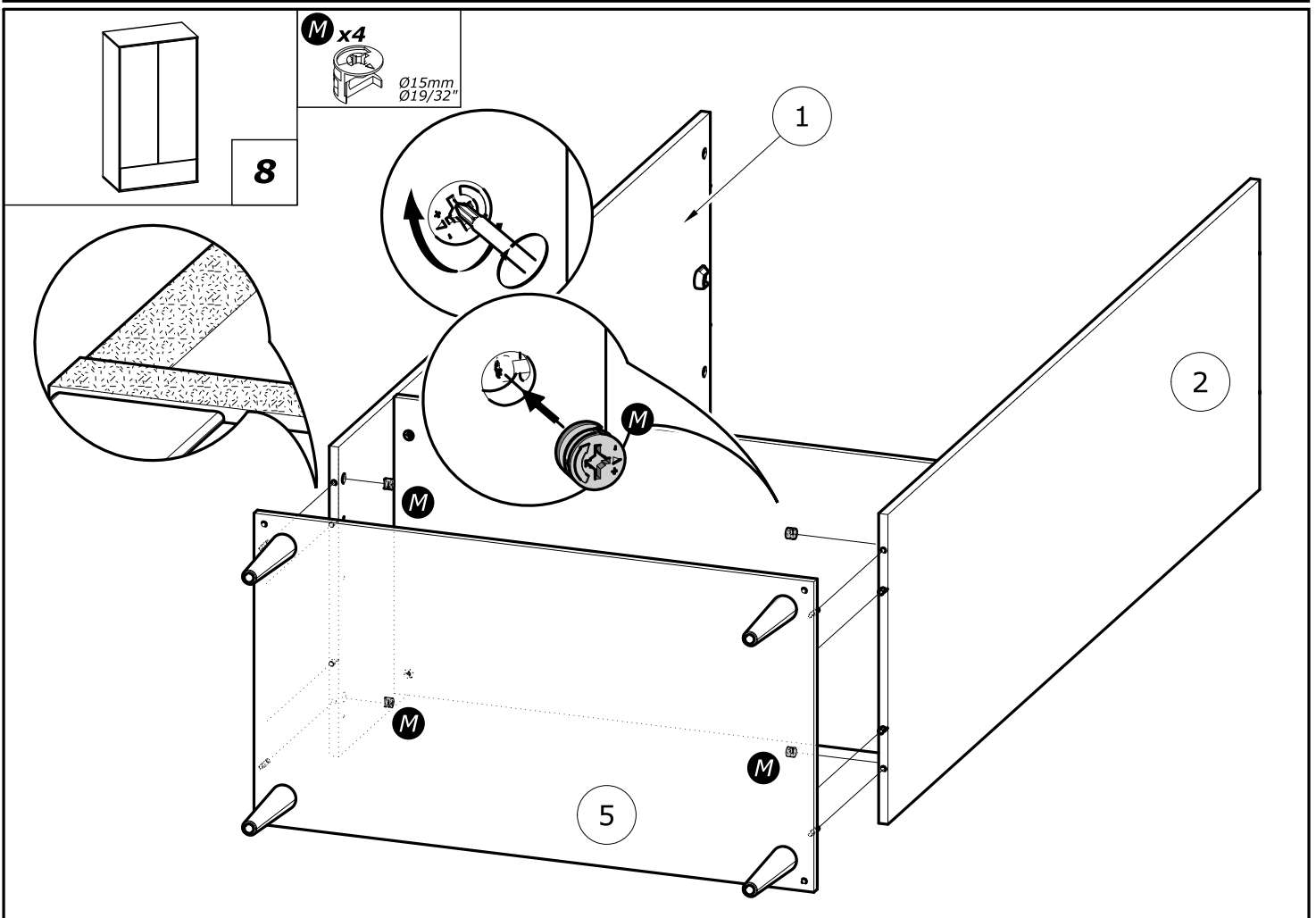
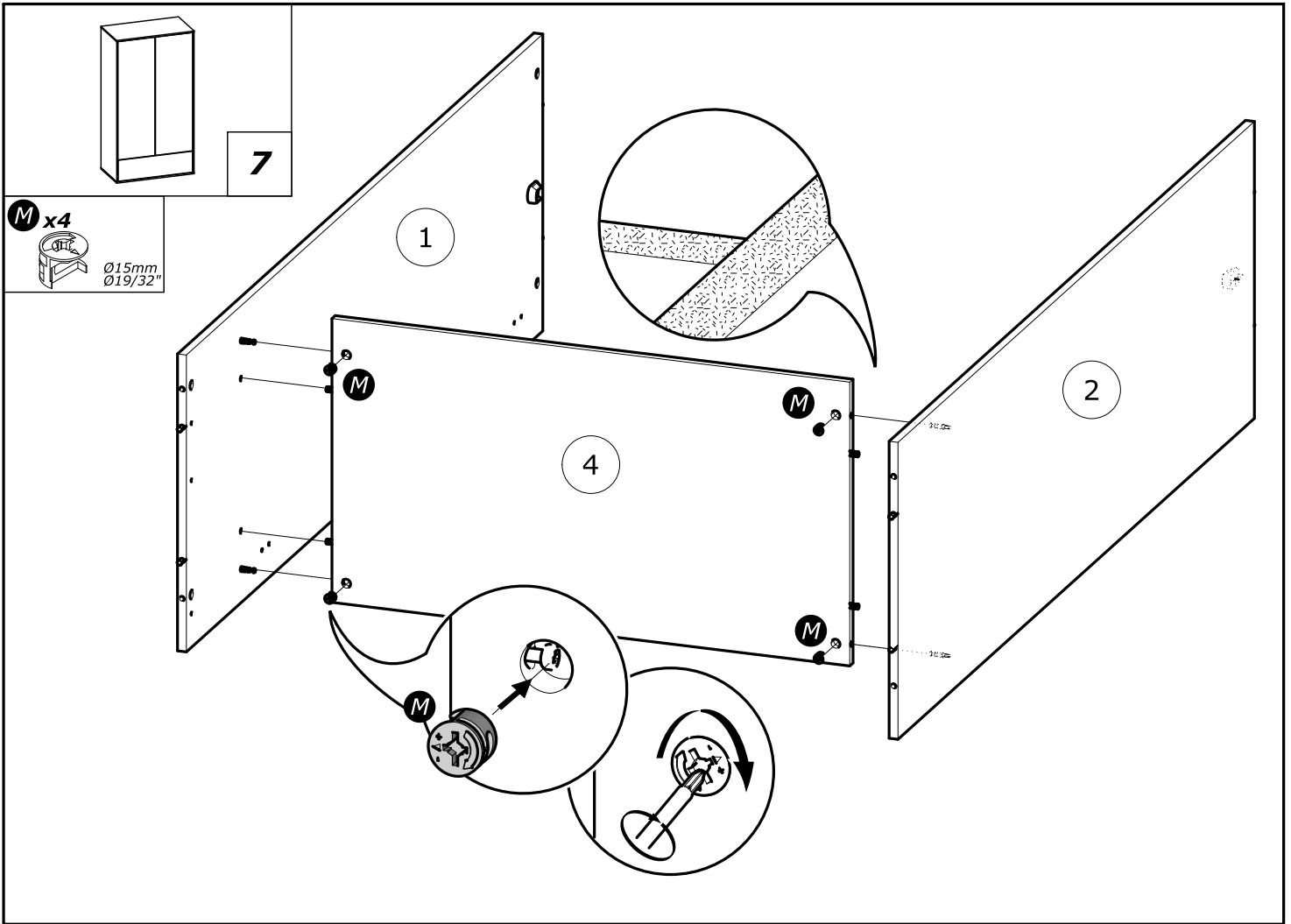

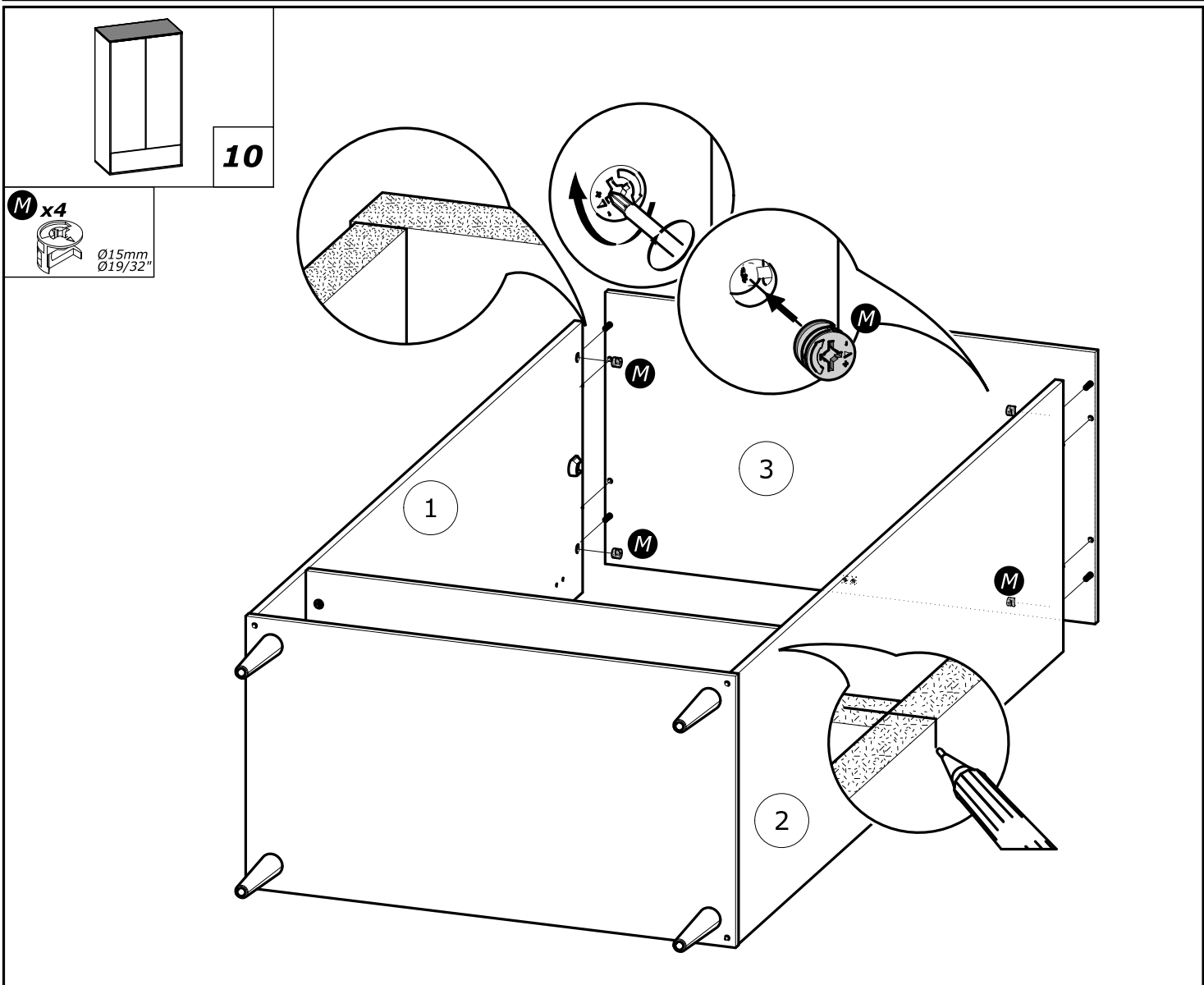
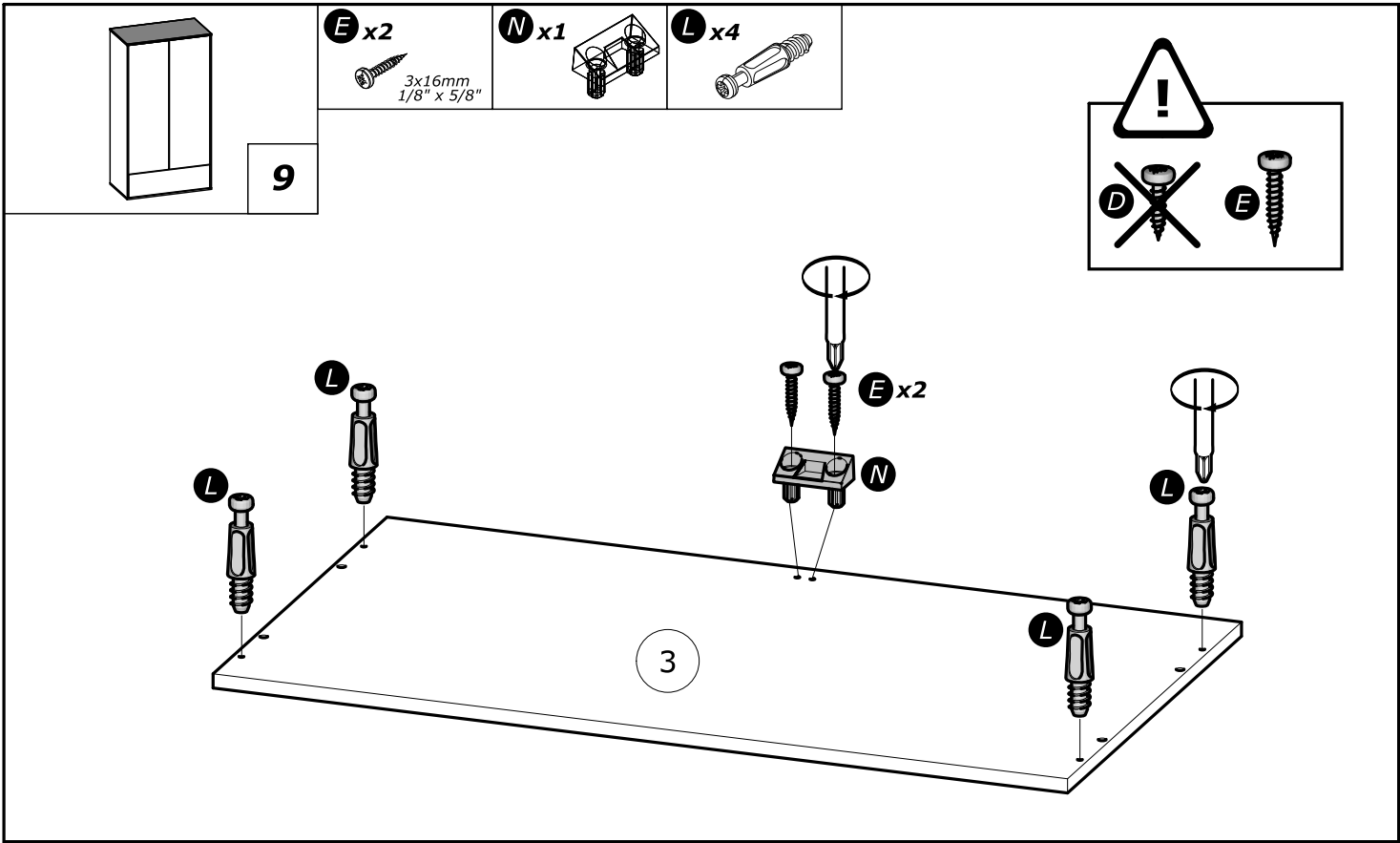



www.Demeyere.fr

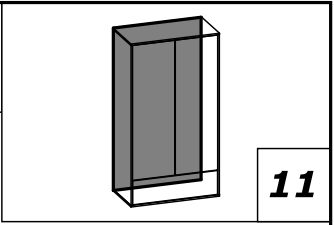
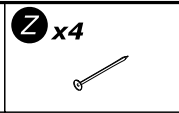
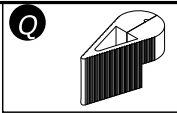

11

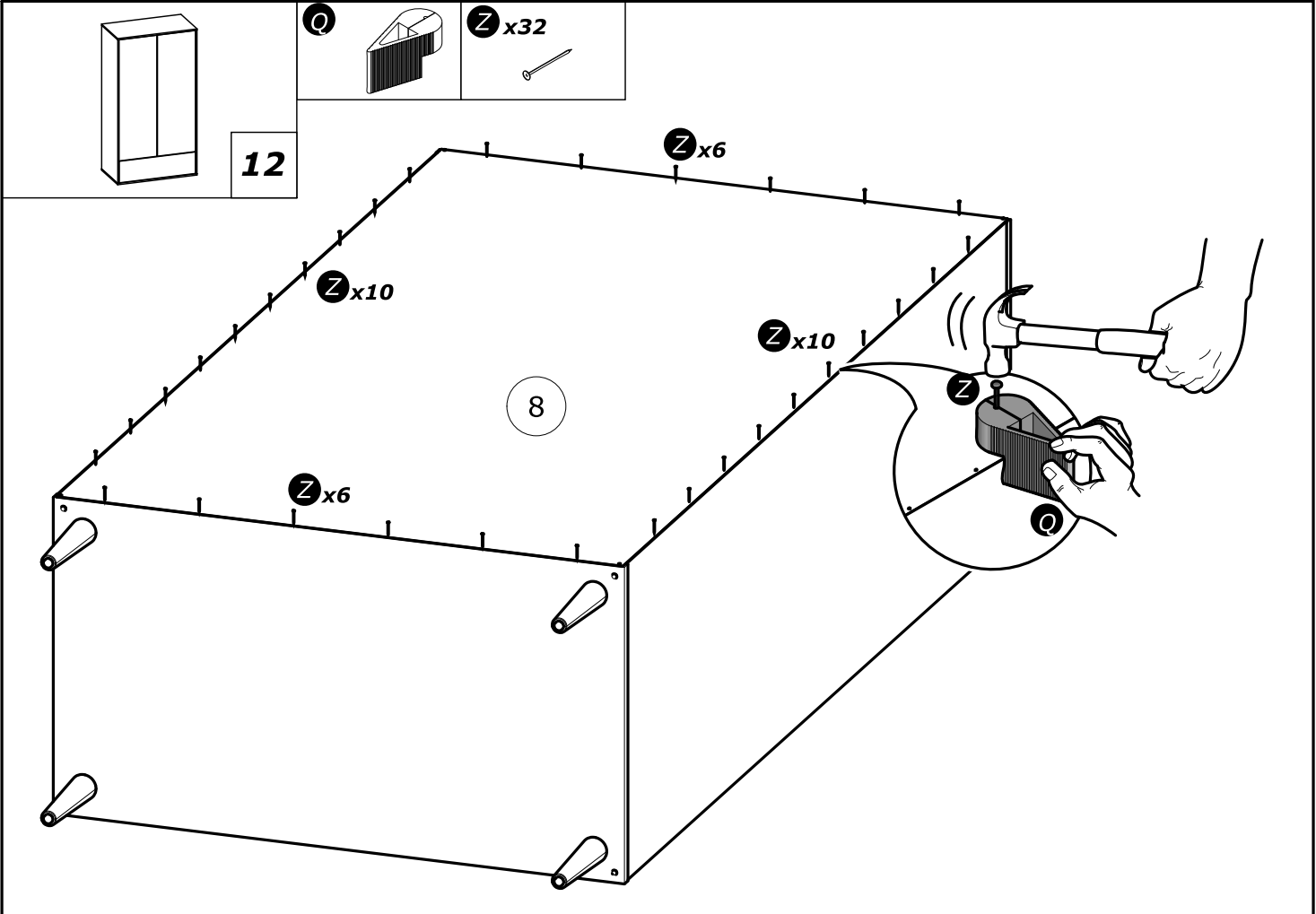
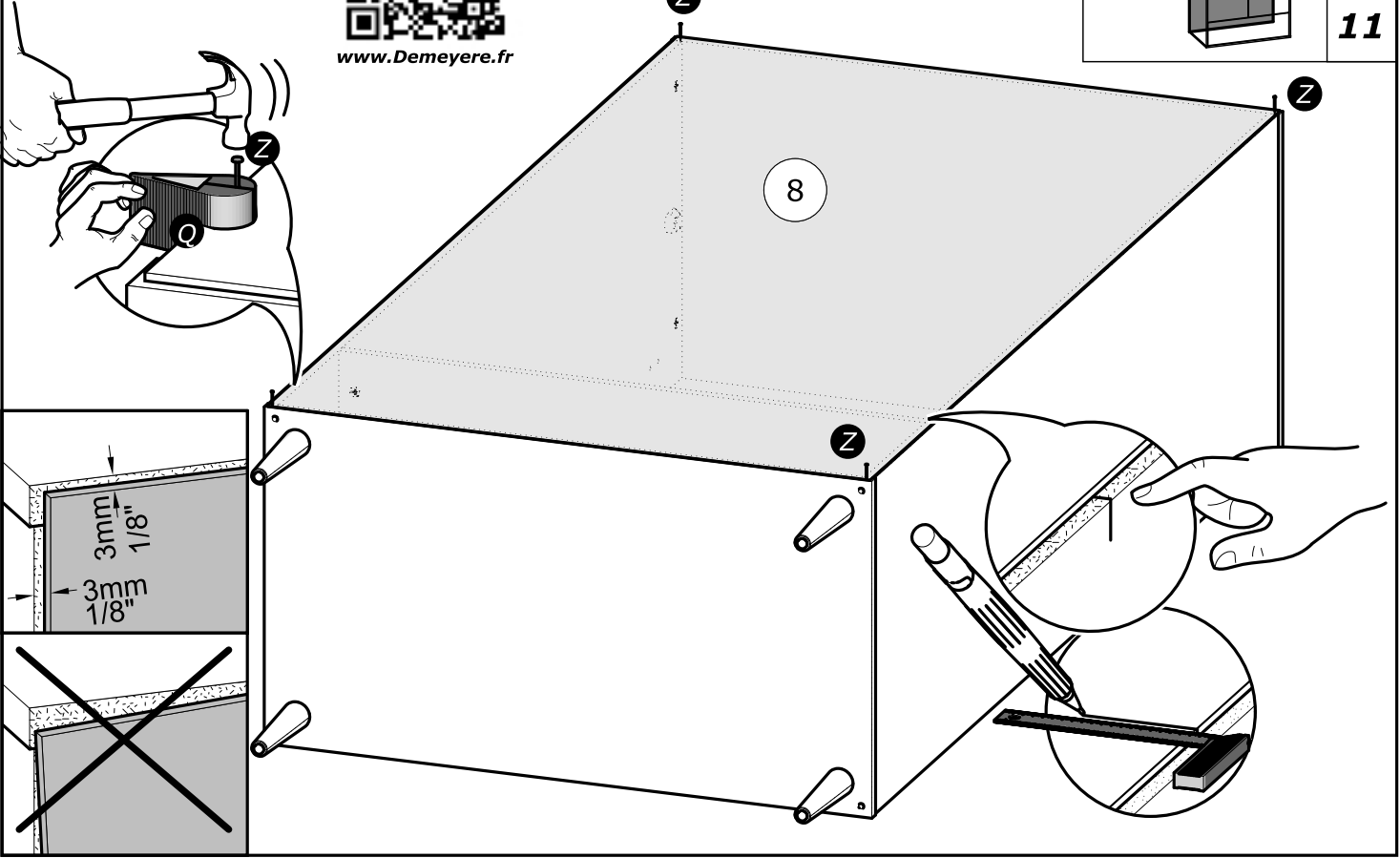

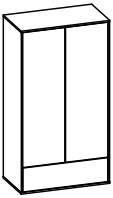

13

Z x6

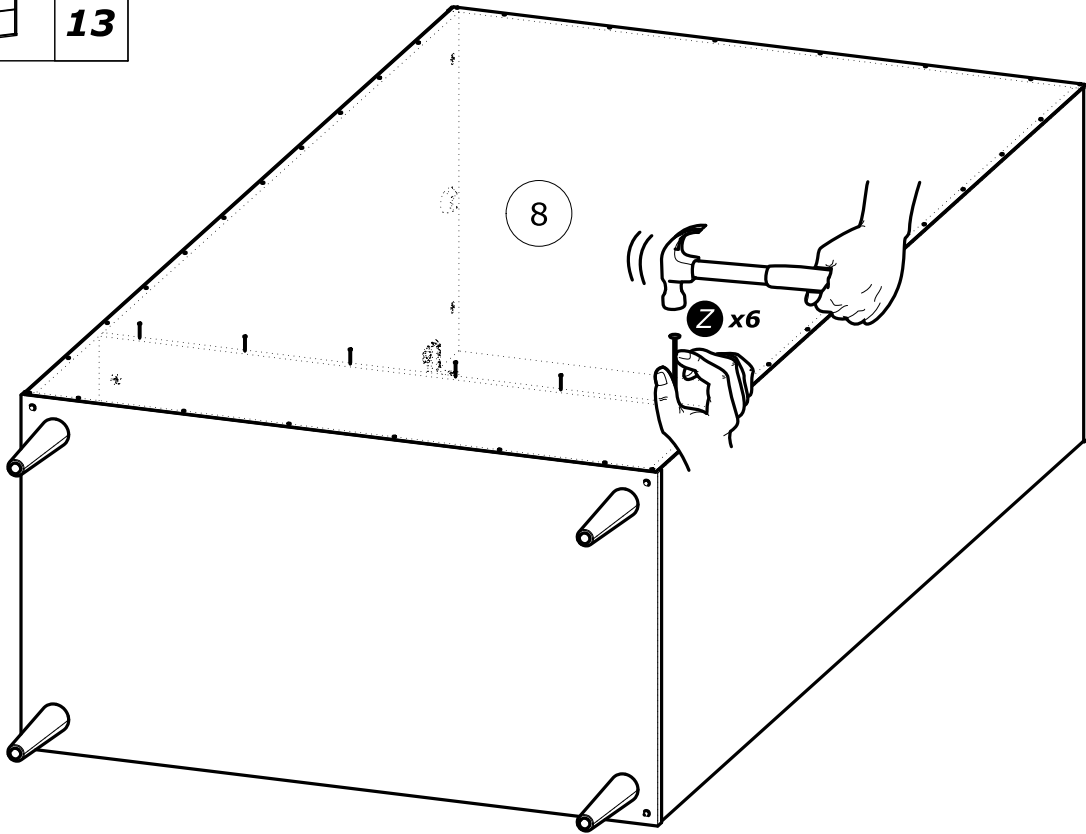

8

Z x6

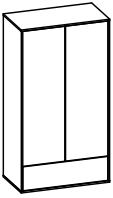

14

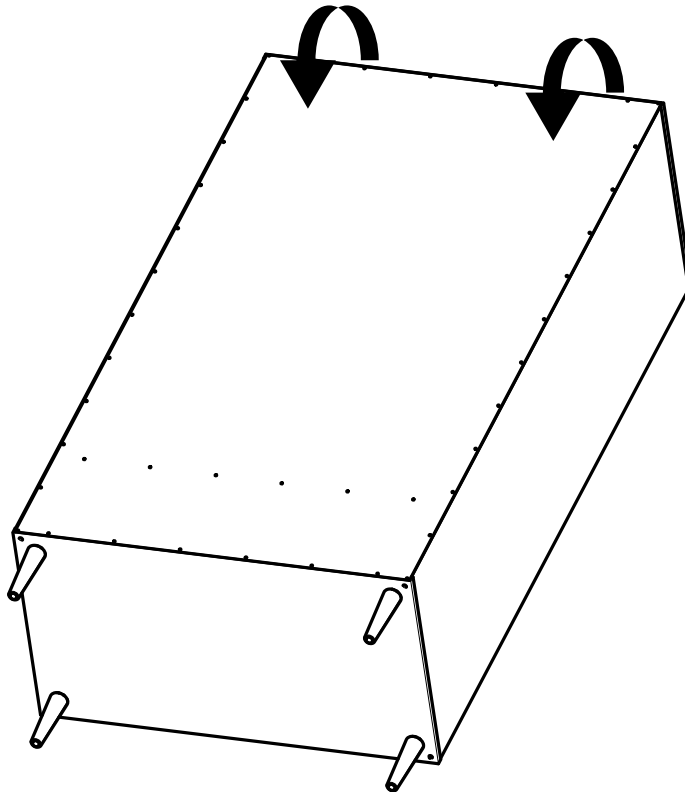

x2

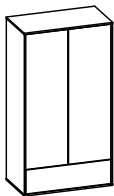

15

E x2
3x16mm
1/8" x 5/8"

U x1

X x1

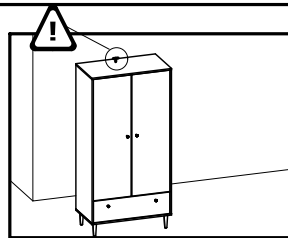
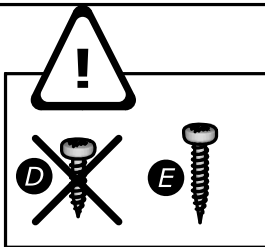

1°

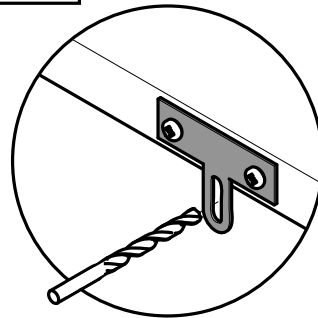
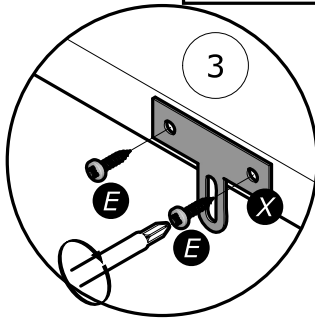
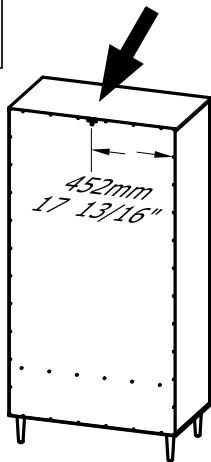

2°

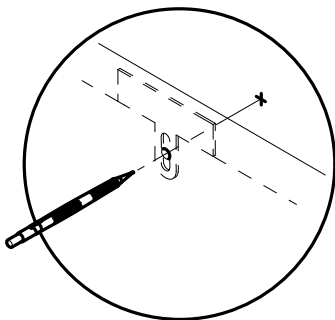
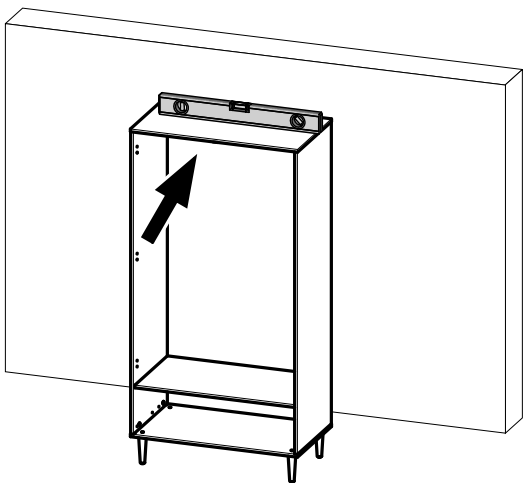

3°

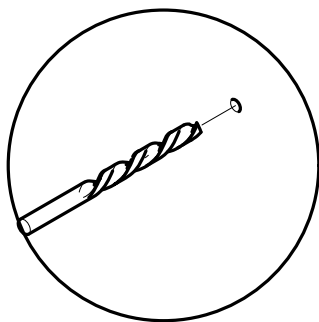
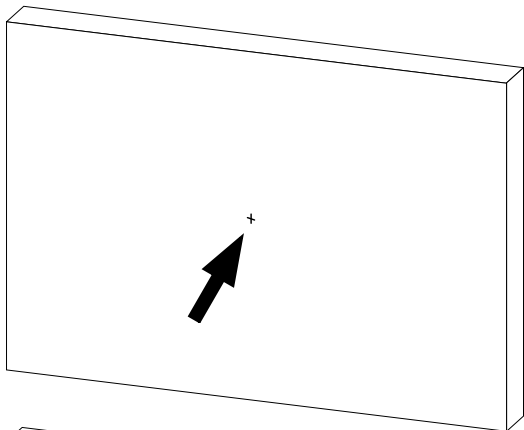

4°

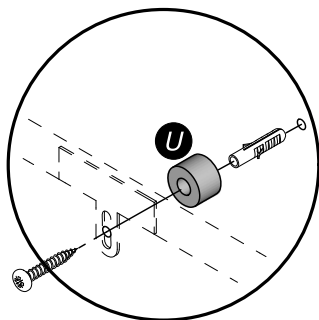
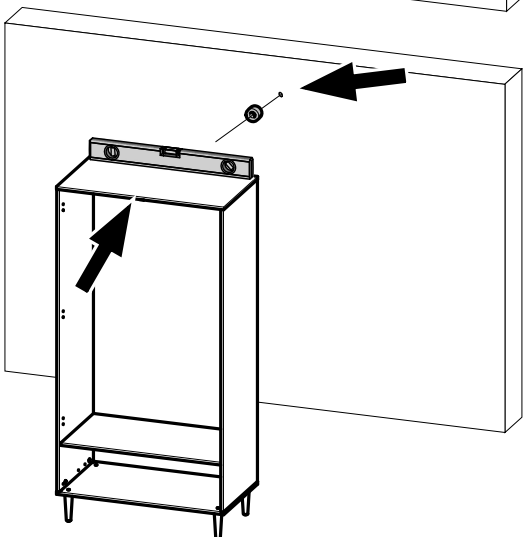

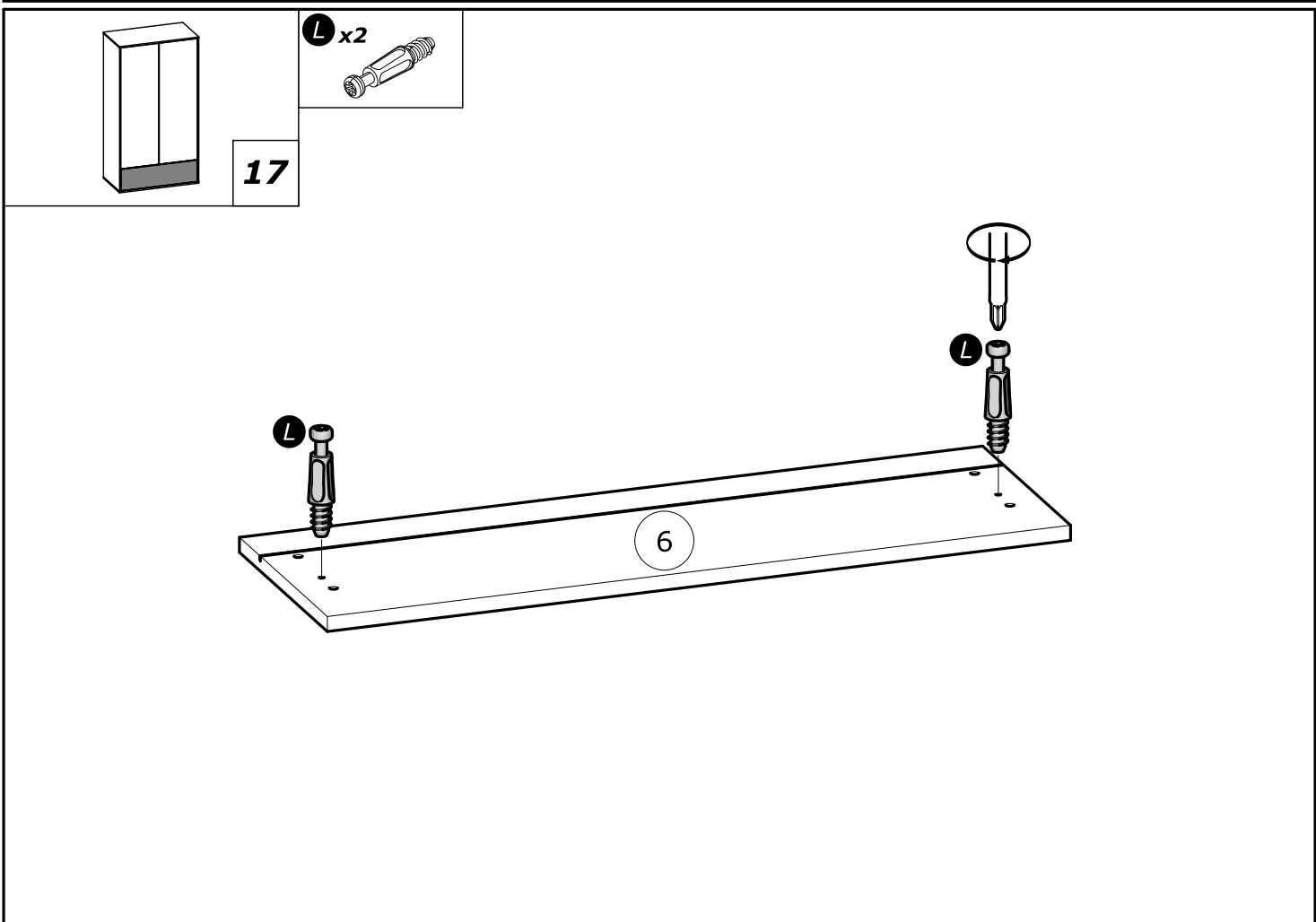
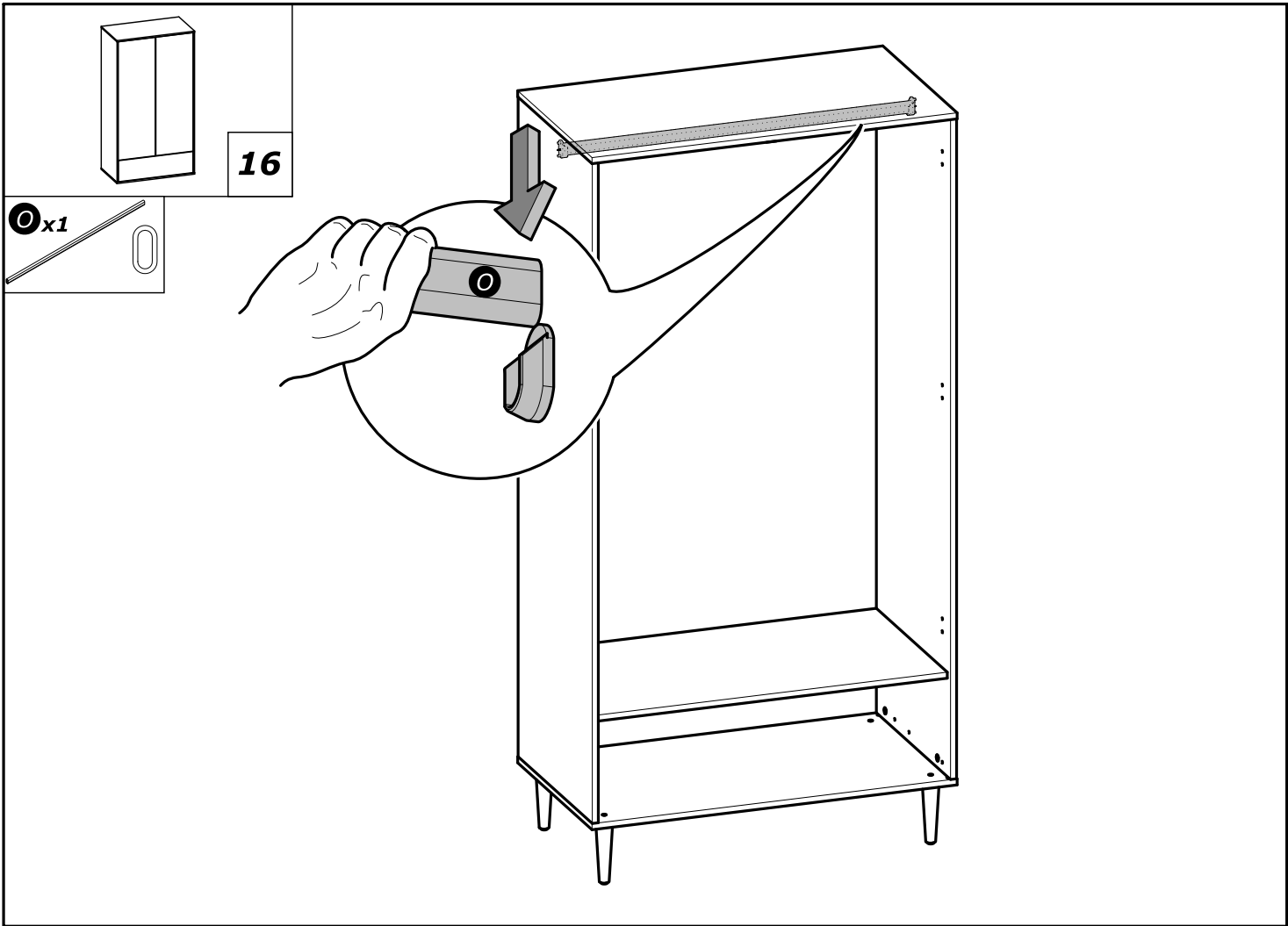

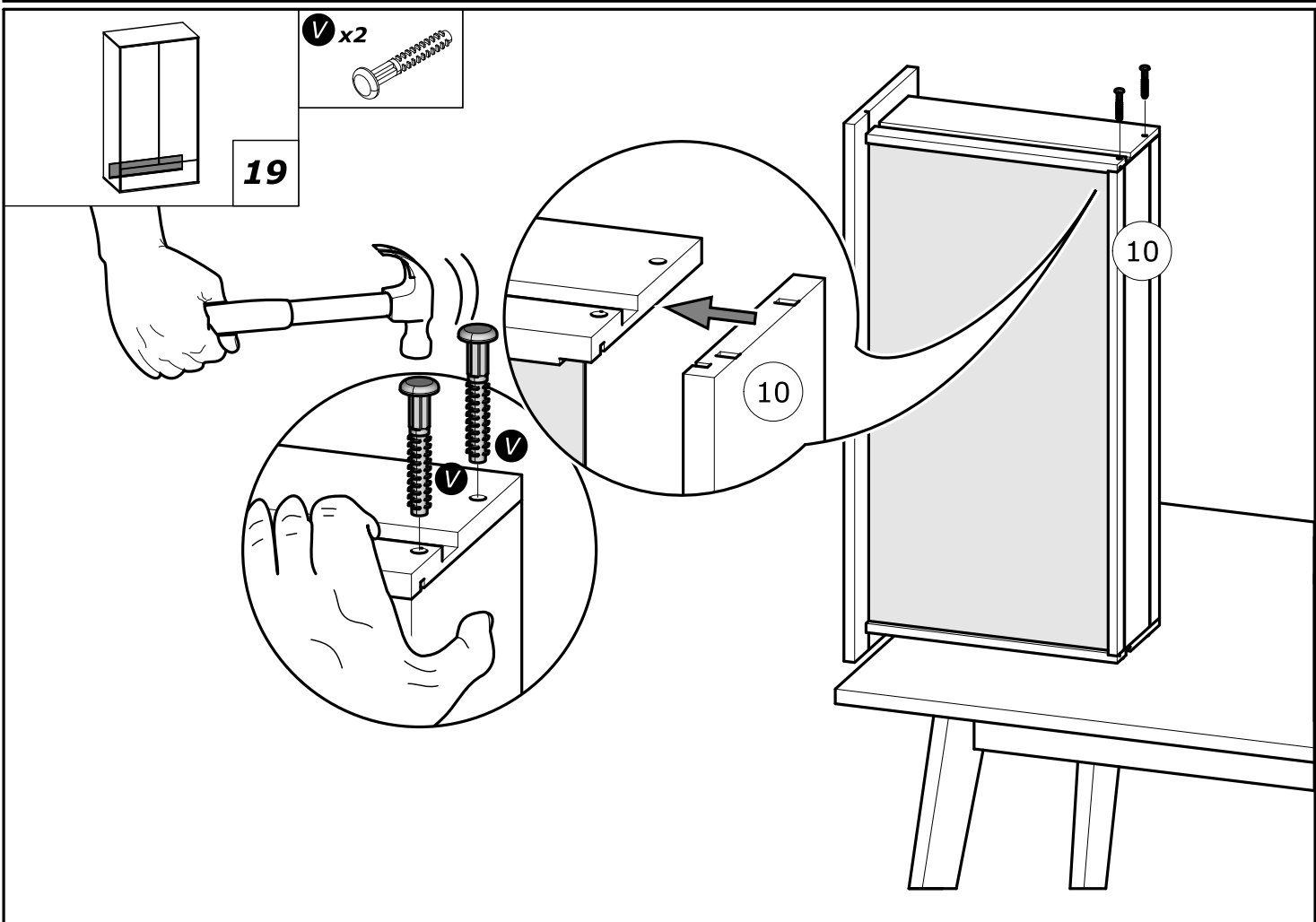
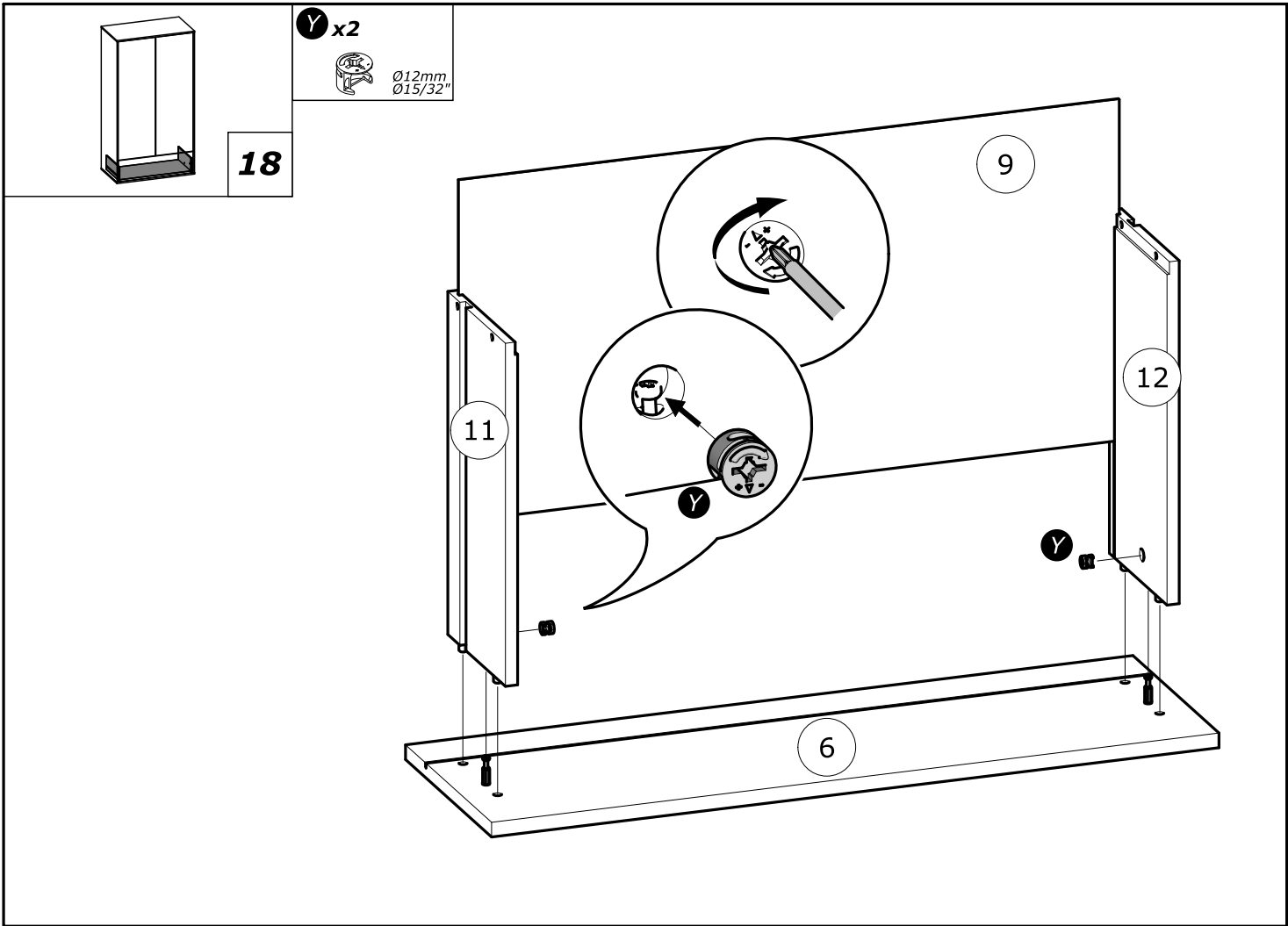

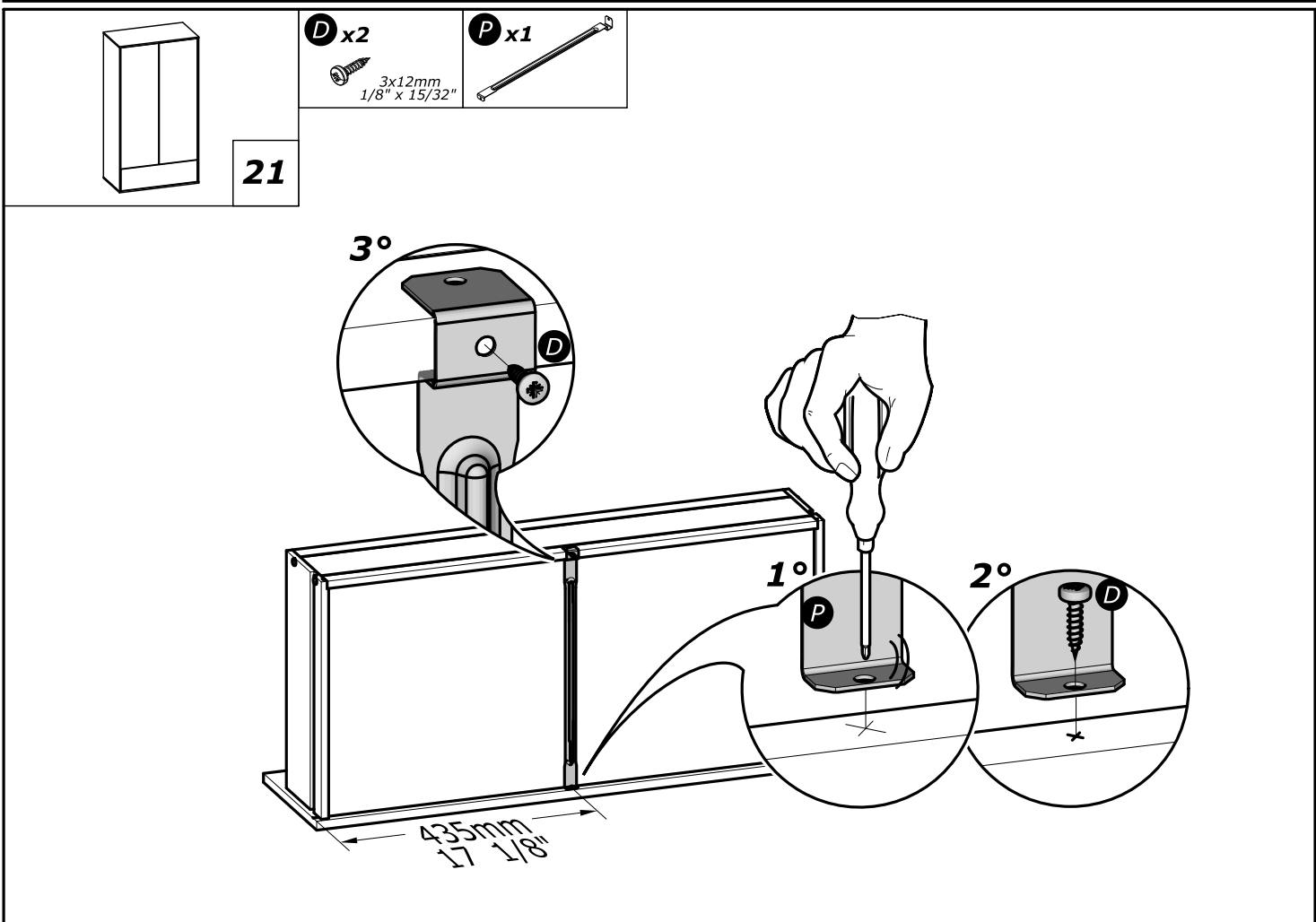
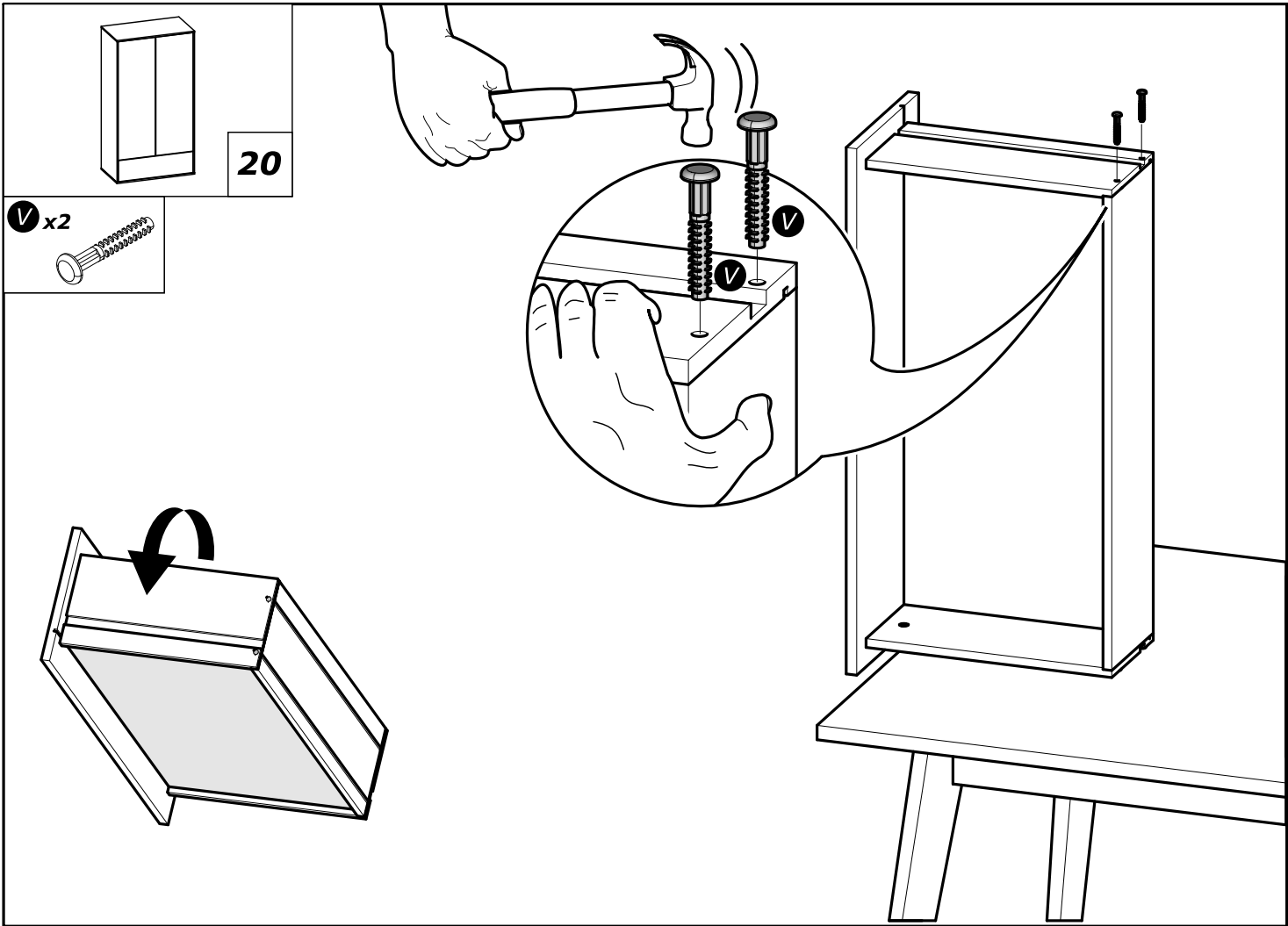

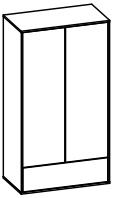

22

G x2
4x25mm
5/32" x 1"

AA x2



www.Demeyere.fr

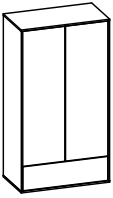
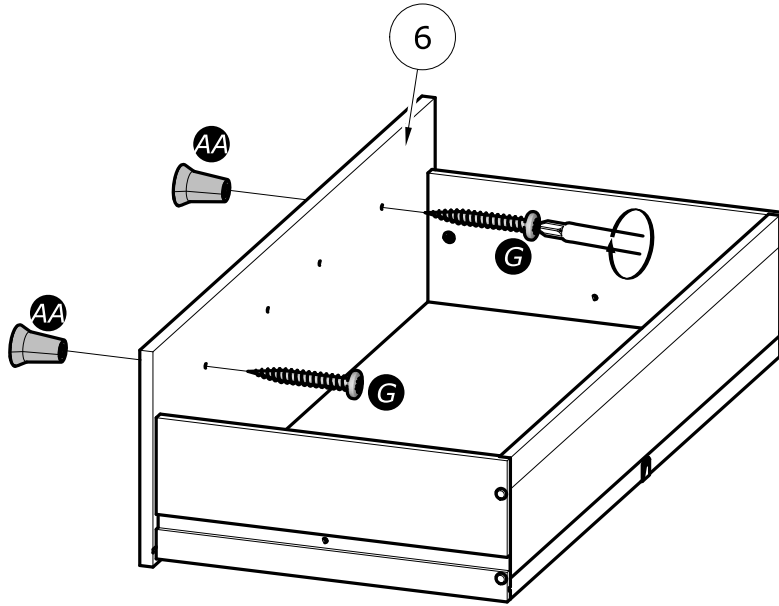
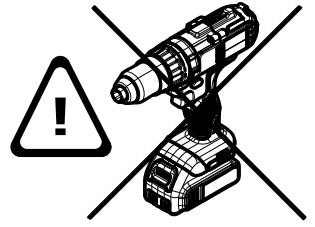

23

B x1

I x4
3x12mm
1/8" x 15/32"



www.Demeyere.fr

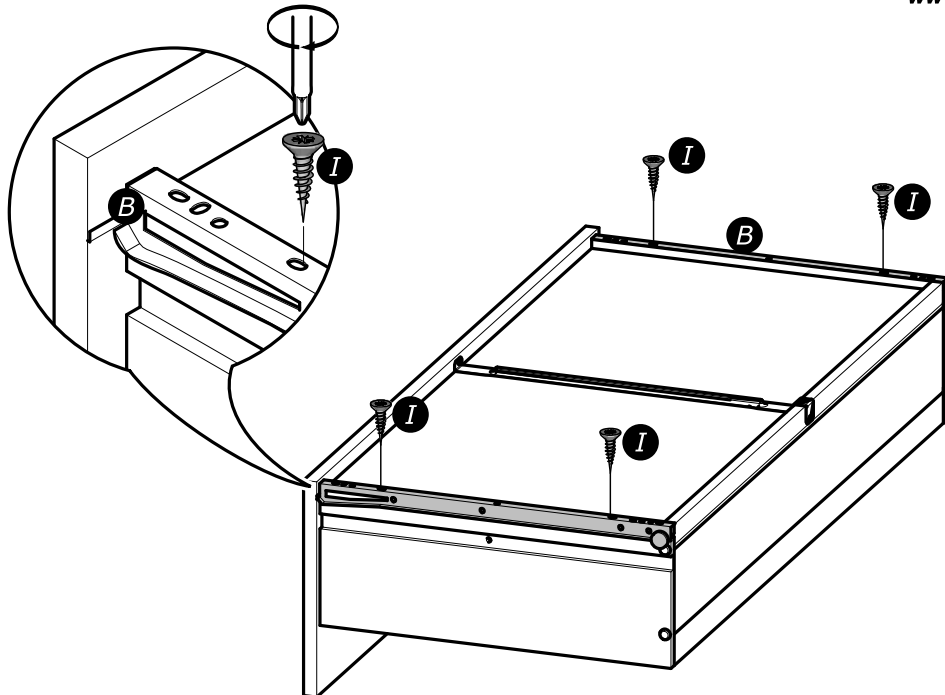

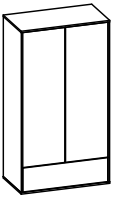

24

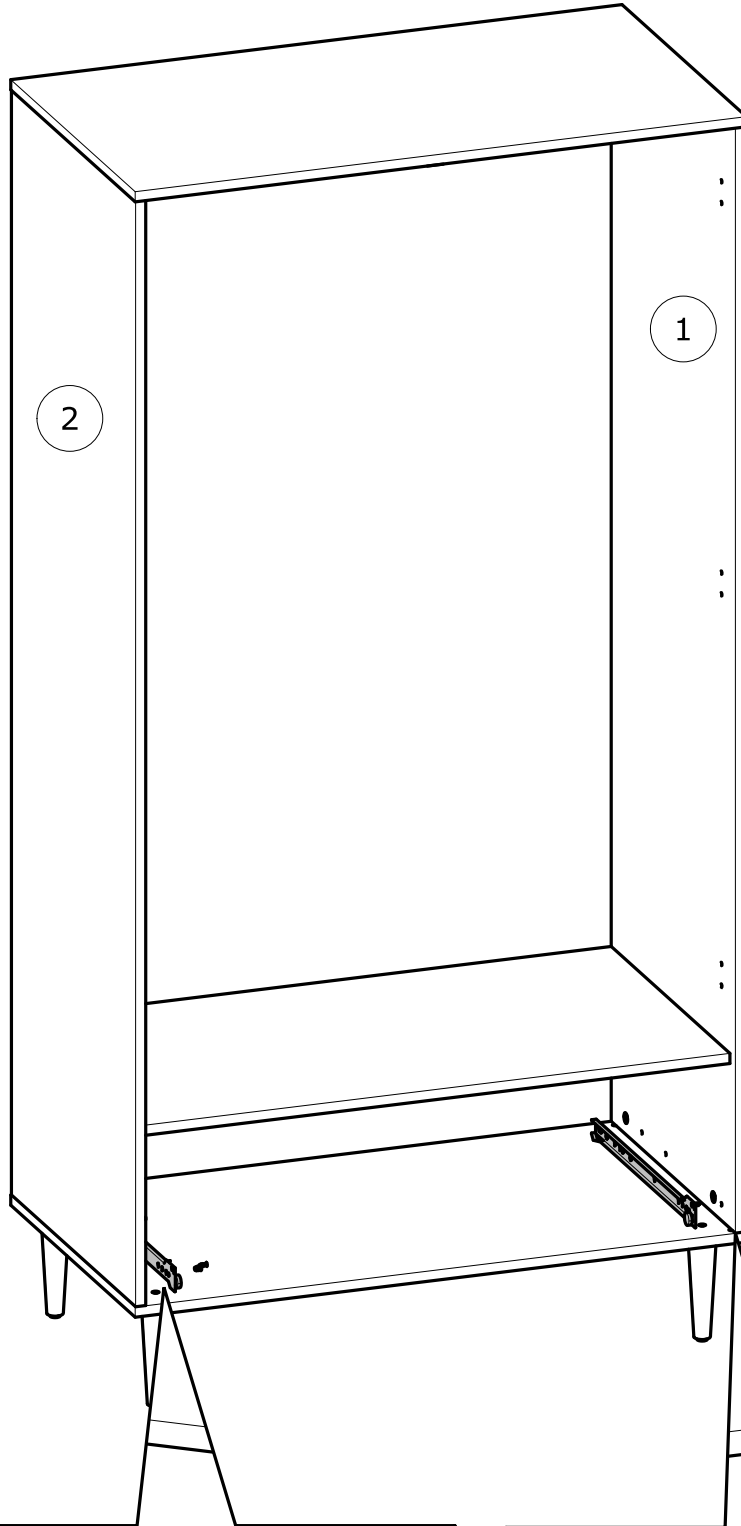
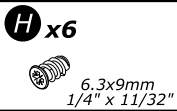
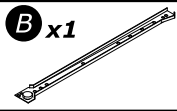
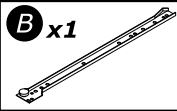

www.Demeyere.fr

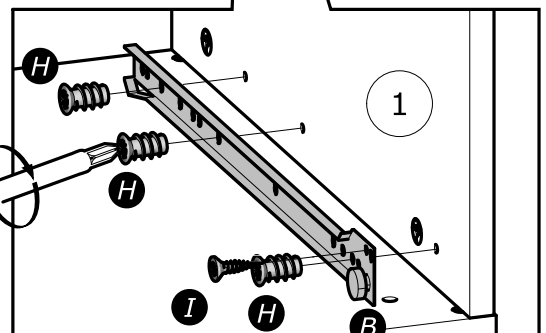
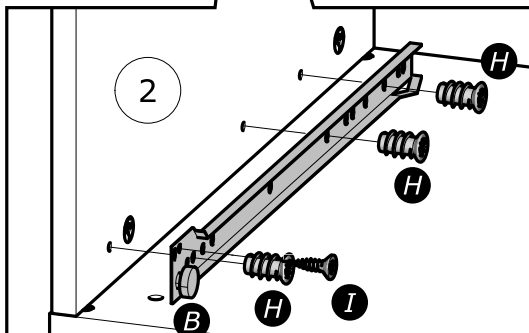

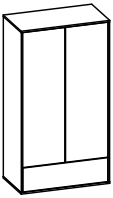

25



www.Demeyere.fr

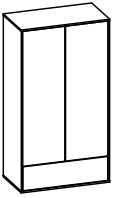
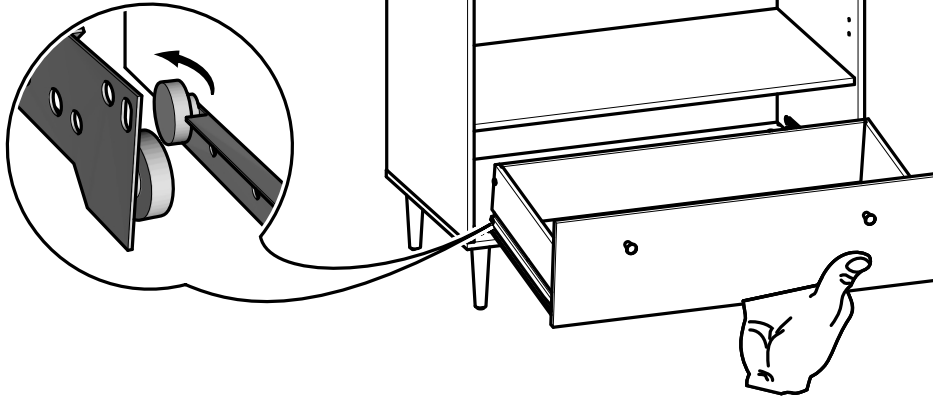

26



www.Demeyere.fr

S x6

H=2mm
H=1/16"

T x6

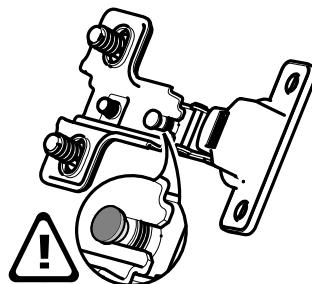
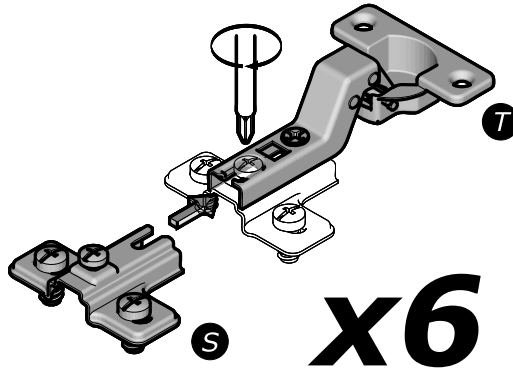

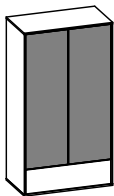

27

J x12

3.5x15mm
1/8" x 19/32"

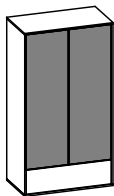
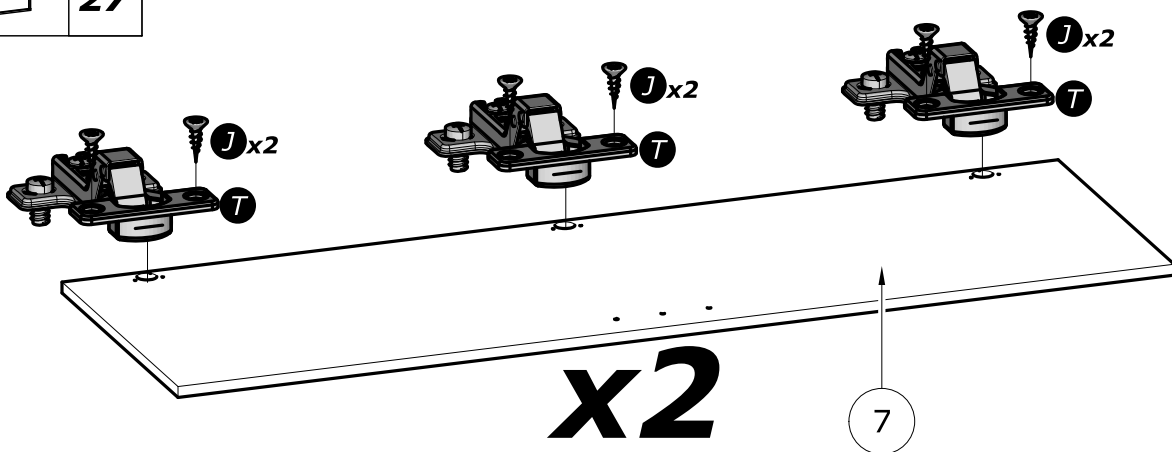

28

G x2

4x25mm
5/32" x 1"

AA x2



x2

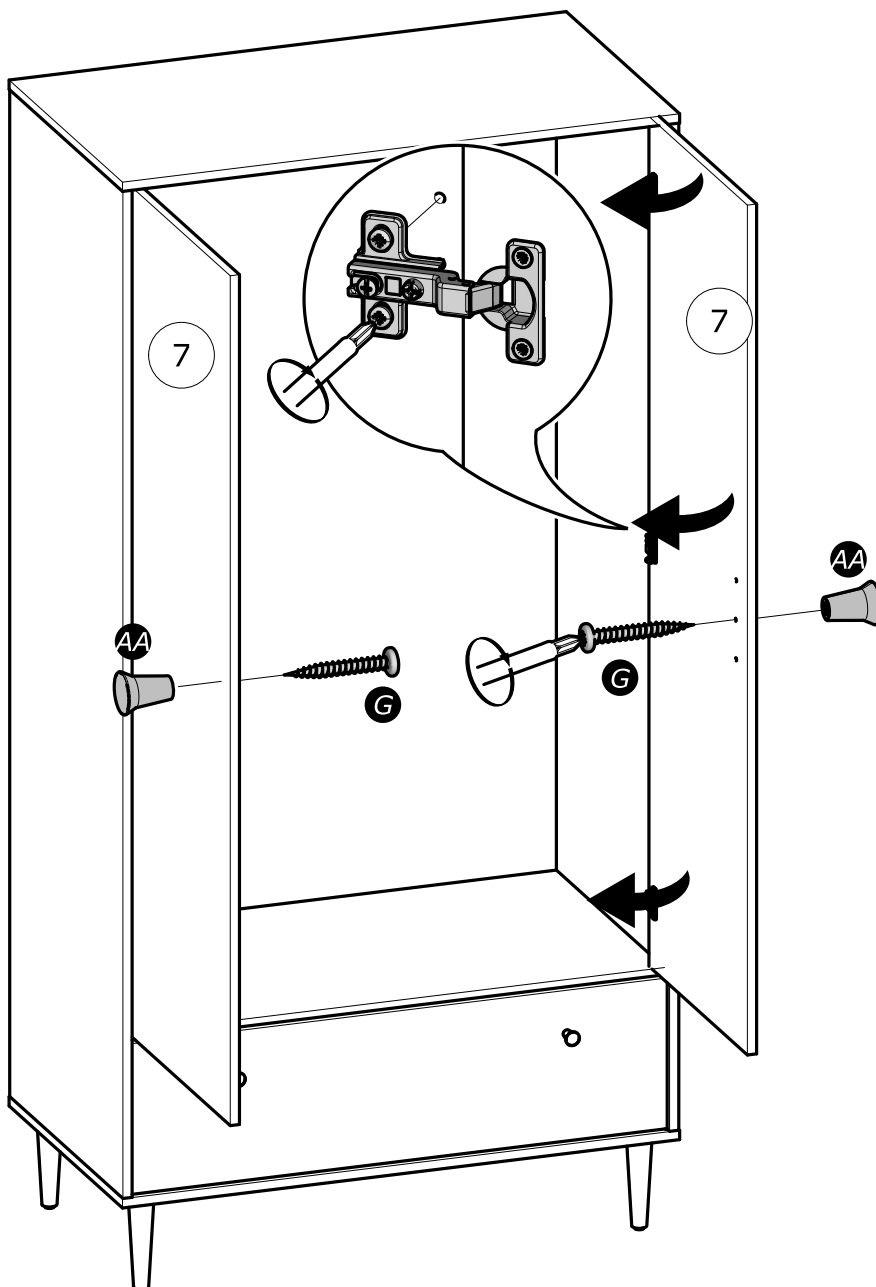
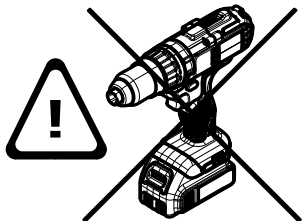

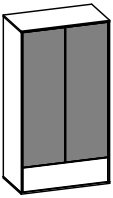

29



www.Demeyere.fr

